

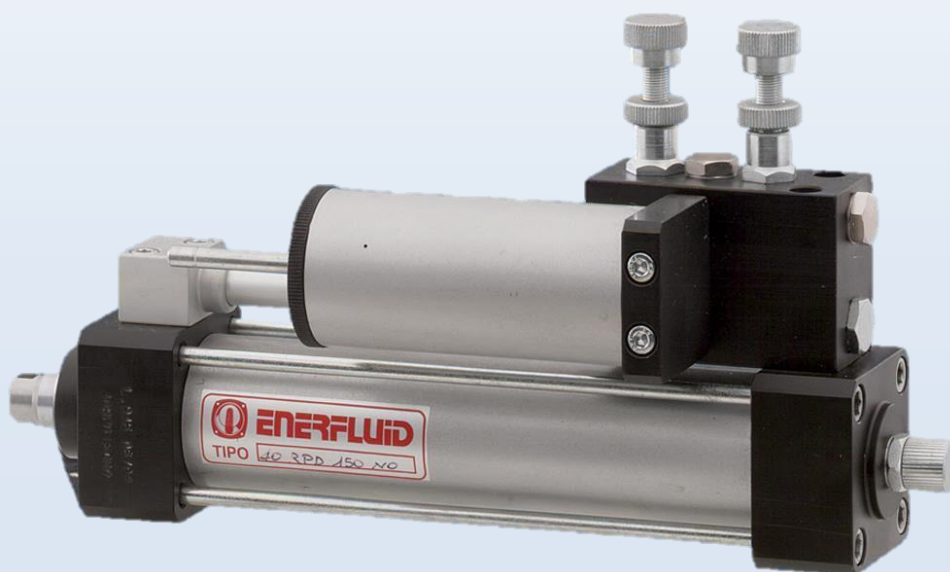

**ENERFLUID**

**CATALOGO TECNICO REGOLATORI DI VELOCITÀ  
HYDRAULIC SPEED REGULATORS TECHNICAL CATALOGUE**



**CATALOGUE TECHNIQUE REGULATEURS DE VITESSE HYDRAULIQUE  
CATÁLOGO TÉCNICO REGULADORES DE VELOCIDAD HIDRÁULICAS**

2016/02



ENERFLUID progetta, costruisce e commercializza da 30 anni regolatori idraulici di velocità, con impegno e tenacia. Con tale impegno ha ottenuto nel 1998 la certificazione del suo Sistema Qualità secondo la norma UNI ISO 9001, con l'obiettivo di soddisfare al meglio la clientela. I prodotti ENERFLUID sono realizzati con macchine CNC ad alta tecnologia. ENERFLUID è presente sul mercato Nazionale, Europeo ed extra Europeo.



Depuis 30 ans, la société ENERFLUID conçoit, fabrique et vente ses régulateurs hydrauliques de vitesse. Cet engagement a permis en 1998 la certification de l'entreprise suivant la norme UNI EN ISO 9001 avec l'objectif de satisfaire au mieux sa clientèle. Les produits ENERFLUID sont réalisés sur machines à commande numérique de haute technologie. ENERFLUID travaille sur le marché National, Européen et Extra-Européen.



With engagement and perseveration, ENERFLUID has been planning, manufacturing and selling hydraulic speed regulators since 30 years. With this engagements, ENERFLUID got the UNI EN ISO 9001 CERTIFICATION of its quality system in 1998, in order to satisfy better its customers. Its products are manufactured by CNC machine tools with high technology. ENERFLUID sales on the National, European and extra-European market.



Desde 30 años, la sociedad ENERFLUID proyecta construye y comercializa con empeño y tenacidad reguladores hidraulicos de velocidad. Este empeño ha permitido en 1998 la cetificación de la sociedad según la norma UNI EN ISO 9001, con l'objetivo de la mejor satisfacción de la clientela. Los productos ENERFLUID son realizaados por màquinas CNC de alta tecnologia. ENERFLUID obra en el mercado nacional, europeo y extra-europeo.

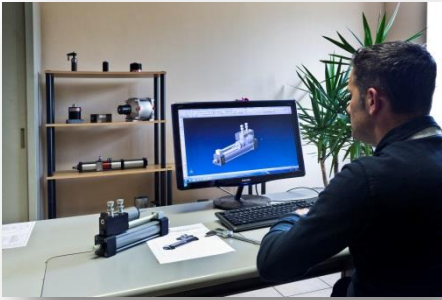

**Reparto tecnico – *Technical department***

ENERFLUID dispone di un ufficio tecnico attrezzato per la progettazione di nuovi prodotti e per fornire soluzioni tecniche personalizzate su richiesta del cliente.

*ENERFLUID has its own technical office equipped for planning new products and for supplying personalized technical solutions under customer demand.*

100% MADE  
IN ITALY

**Reparto commerciale**

***Trade department***

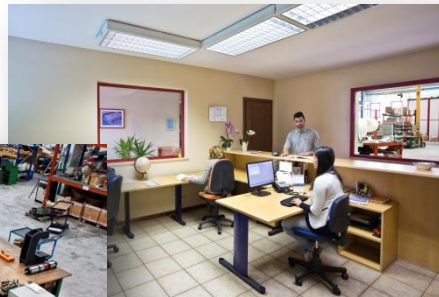

**Reparto assemblaggio**

***Assembly department***

**Reparto produzione – *Production department***

La produzione rappresenta per ENERFLUID il “cuore” dell’azienda. Il 98% dei processi produttivi è svolto internamente, con macchine automatizzate e tradizionali. Si parte dalle materie prime fino ad arrivare ai componenti finiti.

*Production represents for ENERFLUID the “heart” of the company. Automatised and traditional machines make the 98% of production processes internally. We start from raw material till to complete the spare parts.*





Regolatori idraulici di velocità SERIE 25 ..... pag. 4

Istruzioni caricamento olio regolatori SERIE 25 ..... pag. 6

Caratteristiche tecniche generali reg. SERIE 35 - 40..... pag. 7

Regolatori idraulici di velocità SERIE 35 ..... pag. 9

Regolatori idraulici di velocità SERIE 40 ..... pag. 21

Valvole di controllo ..... pag. 33

Accessori ..... pag. 37

Istruzioni caricamento regolatori SERIE 35-40..... pag. 40



Régulateurs hydrauliques de vitesse Séries 25 ..... pag. 5

Instructions pour le remplissage d'huile Séries 25..... pag. 6

Caractéristiques de construction Séries 35 et 40 ..... pag. 8

Régulateurs hydrauliques de vitesse Séries 35 ..... pag. 9

Régulateurs hydrauliques de vitesse Séries 40 ..... pag. 21

Soupapes de contrôle ..... pag. 33

Accessoires ..... pag. 37

Instructions remplissage d'huile Séries 35 et 40 ..... pag.41



Hydraulic speed regulators 25 SERIES ..... pag. 4

Instruction for oil charge regulators 25 SERIES ..... pag. 6

Technical specification regulators 35 – 40 SERIES ..... pag. 7

Hydraulic speed regulators 35 SERIES ..... pag. 9

Hydraulic speed regulators 40 SERIES ..... pag. 21

Control valves ..... pag. 33

Accessories ..... pag. 37

Instruction for oil charge regulators 35-40 series ..... pag. 40



Reguladores hidráulicos de velocidad SERIE 25 ..... pag. 5

Instrucciones para cambio de aceite SERIE 25 ..... pag. 6

Características de fabricación SERIE 35 y 40 ..... pag. 8

Reguladores hidráulicos de velocidad SERIE 35 ..... pag. 9

Reguladores hidráulicos de velocidad SERIE 40 ..... pag. 21

Válvulas de control ..... pag. 33

Acesorios ..... pag. 37

Instrucciones para cambio de aceite SERIE 35 y 40..... pag. 41

# REGOLATORI IDRAULICI DI VELOCITÀ

SISTEMI E TECNOLOGIE PER BLOCCAGGIO – ASSEMBLAGGIO – PRODUZIONE - CONTROLLO DELLA VELOCITÀ E DEGLI EFFETTI DEL MOTO  
SYSTEMS AND TECHNOLOGY FOR LOCKING – ASSEMBLY – PRODUCTION, SPEED AND MOTION CONTROL  
SYSTEMES ET TECHNOLOGIES POUR BLOCCAGE – ASSEMBLAGE – PRODUCTION – CONTRÔLE DE LA VITESSE ET DES EFFETS DU MOUVEMENT  
SISTEMAS Y TECNOLOGIAS PARA BLOQUEAR – MONTAR – PRODUCCION – CONTROL DE LA VELOCIDAD Y DE LOS EFECTOS DEL MOVIMIENTO



Il grande vantaggio di usufruire della velocità e della semplicità di un movimento a comando pneumatico pone anche il problema della comprimibilità dell'aria che rende impossibile un controllo della velocità o l'arresto nei punti prestabiliti. L'applicazione di regolatori idraulici di velocità consente di poter controllare qualsiasi movimento, velocità di lavoro, accelerazione, fasi di regolazione e stop di azioni a comando pneumatico.

## Serie disponibili

**Serie 25 RLE regol. entrata stelo**  
**Serie 35 RLU regol. uscita stelo**  
**35 RPU regol. uscita stelo**  
**35 RPE regol. entrata stelo**  
**35 RPD regol. entrata-uscita stelo**  
**Serie 40 RLU regol. uscita stelo**  
**40 RPU regol. uscita stelo**  
**40 RPE regol. entrata stelo**  
**40 RPD regol. entrata-uscita stelo**



The main advantage of pneumatically controlled systems is that they run quickly and easily, but there are problems in compressing the air, which means it is impossible to control the speed or stop at setpoints. With the hydraulic speed regulator you can control the movements, work speed, acceleration, settings and pneumatic operation stop.

## Series available

**Series 25 RLE piston rod in-stroke setting**  
**Series 35 RLU piston rod out-stroke setting**  
**35 RPU piston rod out-stroke setting**  
**35 RPE piston rod in-stroke setting**  
**35 RPD piston rod in/out-stroke setting**  
**Series 40 RLU piston rod out-stroke setting**  
**40 RPU piston rod out-stroke setting**  
**40 RPE piston rod in-stroke setting**  
**40 RPD piston rod in/out-stroke setting**



Les avantages principaux d'un système de mouvement pneumatique sont sa vitesse et sa simplicité, toutefois, les problèmes de compression de l'air rendent impossible le contrôle de la vitesse ou de l'arrêt sur un point déterminé. L'application des régulateurs hydrauliques de vitesse permet de contrôler tout les mouvements, la vitesse de travail, l'accélération, ainsi que les phases de réglage et d'arrêt dans les opérations a commande pneumatique.

## Séries disponibles

**Série 25 RLE Régulation en entrée de tige**  
**Série 35 RLU Régulation en sortie de tige**  
**35 RPU Régulation en sortie de tige**  
**35 RPE Régulation en entrée de tige**  
**35 RPD Régulation en entrée/ sortie de tige**  
**Série 40 RLU Régulation en sortie de tige**  
**40 RPU Régulation en sortie de tige**  
**40 RPE Régulation en entrée de tige**  
**40 RPD Régulation en entrée/ sortie de tige**



La principal ventaja en los sistemas controlados mediante dispositivos neumáticos es que funcionan rápida y fácilmente, pero se presentan problemas al trabajar con aire comprimido, ello implica la dificultad de controlar la velocidad o la parada en puntos preestablecidos. Mediante la utilización de los reguladores hidráulicos de velocidad es posible controlar estos movimientos de velocidad en trabajo, aceleración, posicionamiento y operaciones de parada neumáticos.

## Series disponibles

**Serie 25 RLE Regulación de entrada vástago**  
**Série 35 RLU Regulación de salida vástago**  
**35 RPU Regulación de salida vástago**  
**35 RPE Regulación de entrada vástago**  
**35 RPD Regulación de entrada-salida vástago**  
**Série 40 RLU Regulación de salida vástago**  
**40 RPU Regulación de salida vástago**  
**40 RPE Regulación de entrada vástago**  
**40 RPD Regulación de entrada-salida vástago**

# Regolatori idraulici di velocità – Serie 25

## Hydraulic speed regulators – 25 Series



### DESCRIZIONE

Schematicamente il regolatore di velocità è un circuito idraulico chiuso, privo di una propria sorgente di potenza. Consiste in un cilindro riempito d'olio, uno stelo con relativo pistone, una valvola di regolazione, un serbatoio di compensazione.

Quando lo stelo del regolatore riceve l'urto di una massa in movimento, il pistone si muove chiudendo una valvola unidirezionale.

L'olio quindi viene forzato verso la valvola di regolazione a spillo dove trova una restrizione variabile dall'esterno.

Dopo la valvola di regolazione l'olio fluisce nell'altra camera separata tramite pistone.

Durante il movimento di ritorno comandato da una molla, la valvola unidirezionale si apre e l'olio fluisce senza ostacoli permettendo un rapido movimento di ritorno.

### APPLICAZIONI

Controllo della velocità, nella parte finale, di unità di avanzamento, foratrici, cilindri pneumatici e masse in movimento.

Regolazione in entrata stelo – Disponibili in 3 modelli – Ritorno a molla  
Piston rod in-stroke setting – 3 models available – Spring return

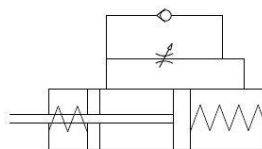
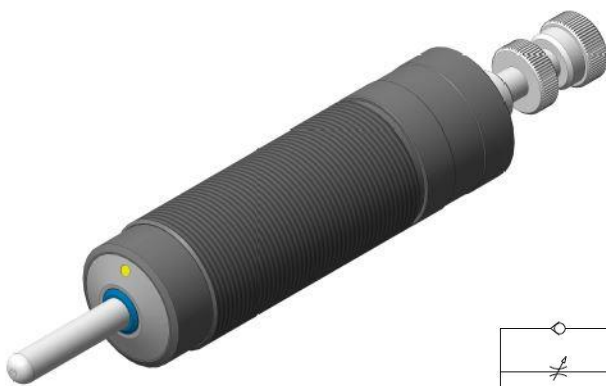

### VELOCITA'

La velocità è regolabile.

**Le variazioni della temperatura provocano modifiche di viscosità dell'olio e quindi piccole variazioni di velocità.**

### CARATTERISTICHE COSTRUTTIVE

- Alesaggio Diametro 25 mm.
- Corpo filettato Acciaio Brunito.
- Stelo Acciaio C45 cromato
- Pistone Alluminio
- Guarnizioni NBR – Poliuretano
- Olio Siliconico, viscosità 250 cSt

### CARATTERISTICHE TECNICHE

- Carico max. controllabile 250Kgf. Comprese inerzie di masse in movimento
- Velocità min e max. 10-3000 mm./min.
- Temperatura di esercizio -10° C/ +60°C

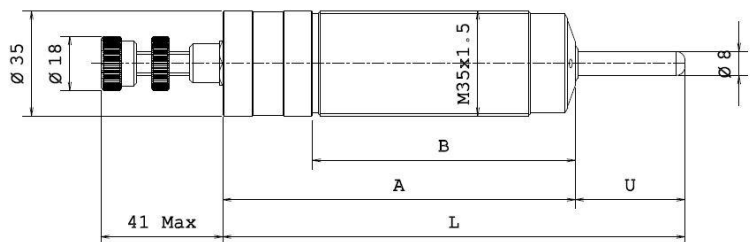

MODELLO MODEL	CORSA IN MM STROKE IN MM	Dimensioni / Dimensions			
		A	B	L	U
<b>RLE.25.25A</b>	25	118	88	153	35
<b>RLE.25.50B</b>	50	164	124	224	60
<b>RLE.25.75B</b>	75	200	150	293	93



### DESCRIPTION

The speed regulator is basically a closed hydraulic circuit without its own power source. It consists of a cylinder filled without oil, a piston rod with piston, a control valve and compensation tank.

When the regulator rod receives the thrust of a moving mass, the piston moves and closes the one way valve. This forces the oil towards the pin control valve where it encounters a restriction that can be adjusted externally. The oil flows through the control valve into the other chamber which is separated by the piston.

During the return movement controlled by a spring, the one-way valve opens and the oil flows freely to enable a rapid return movement.

### APPLICATIONS

End-stage speed control of feed units, perforating machines, pneumatic cylinders and moving masses

### SPEED

The speed can be regulated.

**Temperature variations alter the viscosity of the oil and hence slightly affect the speed.**

### TECHNICAL CHARACTERISTICS

- Bore 25mm diameter
- Threaded body Burnished steel
- Piston rod C45 chromium plated steel
- Gaskets NBR and polyurethane
- Oil Silicone type, 250 cSt viscosity
- Maximum adjustable force 250 kgf. Including any inertia developed by moving masses
- Minimum and maximum speed from 10 to 3000 mm./min.
- Working temperature from -10°C to +60°C

# Régulateurs hydrauliques de vitesse Série 25

## Reguladores hidráulicos de velocidad Serie 25



### DESCRIPTION

Un régulateur de vitesse est essentiellement un circuit hydraulique fermé dépourvu d'une source de puissance qui lui est propre.

Il est constitué d'un cylindre rempli d'huile, d'un piston-tige, d'une soupape de réglage et d'un réservoir de compensation.

Lorsque la tige du régulateur est heurtée par une masse en mouvement, le piston se met en mouvement et ferme une soupape unidirectionnelle.

L'huile circule dans la vanne pointeau réglable.

Après la vanne de réglage, l'huile s'écoule dans une autre chambre séparée du piston.

Pendant le mouvement de retour commandé par un ressort, la soupape unidirectionnelle s'ouvre et l'huile s'écoule sans obstacle, de façon ce que le mouvement de retour soit rapide.

### APPLICATIONS

Contrôle de la vitesse dans la phase finale d'unités d'alimentation, de perceuses, de vérins pneumatiques et de masses en mouvement.

Régulation en entrée de tige – 3 modèles disponibles – Retour à ressort.

Regulación de entrada vástago – disponible en 3 modelos – Regreso para resorte

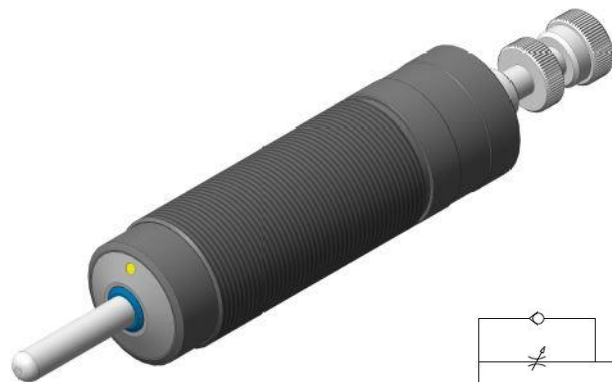

### VITESSE

La vitesse peut être réglée.

**Les variations de température entraînant des changements de viscosité de l'huile, et donc de légères variations de vitesse.**

### CARACTERISTIQUE DE CONSTRUCTION

-Alésage	Diamètre 25mm
-Corps fileté	Acier bruni
-Tige	Acier c45 chromé
-Piston	Aluminium
-Joints	NBR – Polyuréthane
-huile	Siliconée, viscosité 250 cSt

### CARACTERISTIQUE TECHNIQUES

- Charge max. contrôlable	250 kgf., y compris inertie des masses en mouvement.
- Vitesse min. et max.	10-3000 mm/min.
- Température de service	-10°C / + 60°C

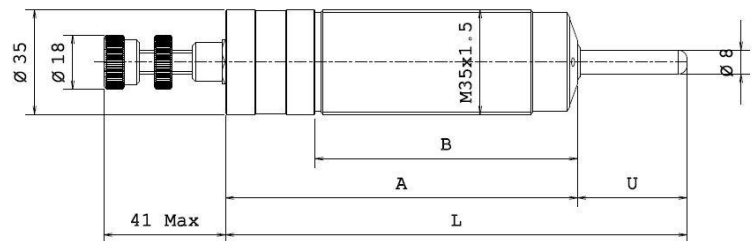

MODÈLE MODELO	COURSE MM CARRERA MM	Dimensions / Tamaños			
		A	B	L	U
<b>RLE.25.25A</b>	25	118	88	153	35
<b>RLE.25.50B</b>	50	164	124	224	60
<b>RLE.25.75B</b>	75	200	150	293	93



### DESCRIPCION

El regulador hidráulico de velocidad es básicamente un circuito hidráulico cerrado sin propio poder de alimentación.

Ello consiste en un cilindro relleno de aceite, un vástago y un depósito de aceite compensador.

Cuando el vástago del regulador recibe el empuje de una masa en movimiento, el embolo se desplaza cerrando la válvula. Esto fuerza el aceite a atravesar la válvula de regulación donde encuentra una restricción que puede ser graduada externamente mediante el giro de un pomo regulador.

El aceite fluye y pasa a la otra cámara la cual se encuentra separada por el embolo. Durante el movimiento de retorno (controlado para un resorte), la válvula de un vía se abre y el aceite fluye libremente permitiendo un rápido movimiento de regreso.

### APLICACIONES

Control de la velocidad en la parte final, de unidad de avance, perforadoras, cilindros neumáticos y masas en movimiento.

### VELOCIDAD

La velocidad puede ser regulada.

**Las variaciones de temperatura provocan una alteración de la viscosidad del aceite y por lo tanto afectan ligeramente a la velocidad.**

### CARACTERISTICAS DE FABRICACION

-Diámetro interior	25mm
-Cuerpo roscado	Acero pavonado
-Barra	Acero C45 cromado
-Pistón	Alluminio
-Juntas	Nbr – poliuretano
-Aceite	A silicone, viscosidad 250 cSt

### CARACTERISTICAS TECNICAS

-Carga máx.controlable	250 kgf. incluidas inercias de masas en movimiento
-Velocidad mín. y máx	10-3000 mm/min.
-Temperatura de trabajo	-10°C/ +60°C

# Regolatori idraulici di velocità - Hydraulic speed regulators Régulateurs hydrauliques de vitesse Reguladores hidráulicos de velocidad



## ISTRUZIONI PER RIEMPIMENTO O RIPRISTINO OLIO

### REGOLATORI SERIE 25

1° - Svitare il tappo pos.2 in senso antiorario con apposita chiave o altro e toglierlo.

**!** Si raccomanda di usare esclusivamente olio al silicone tipo **DOW CORNING 200 FLUID est. 250.**

2° - Riempire con olio la camera pos. 3 fino al limite della filettatura indicato con la lettera "L".

3° - Riavvitare il tappo pos. 2 in senso orario, l'olio in eccedenza uscirà durante l'avvitamento.

-Ora il freno è ricaricato, compreso il serbatoio di riserva.

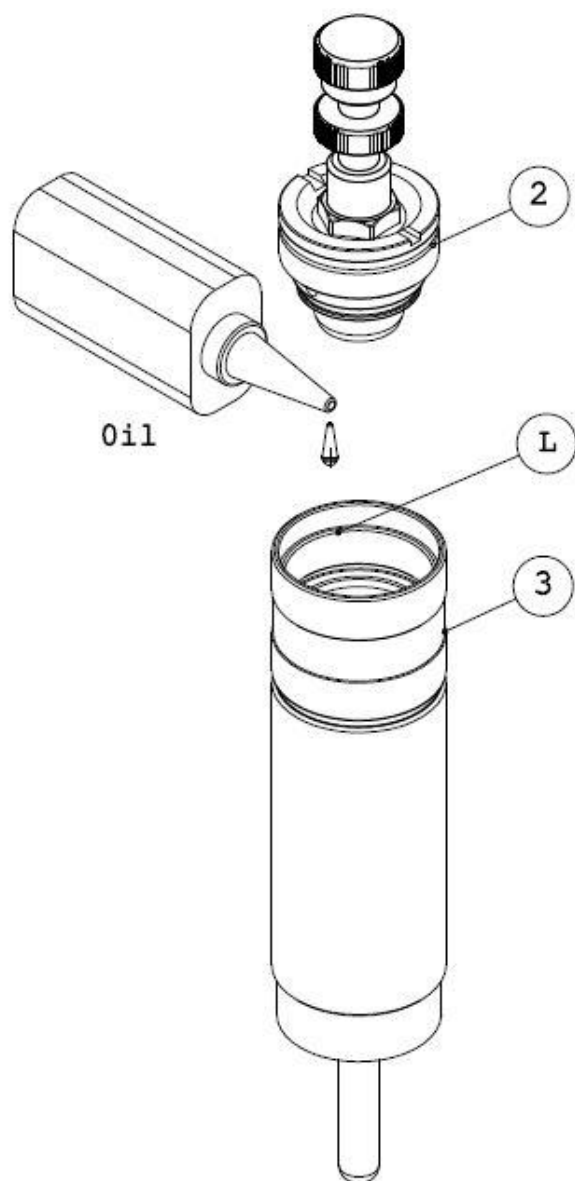

## INSTRUCTION FOR OIL CHARGEMENT AND RESTORE

### REGULATORS 25 SERIES

1st – Unscrew the cap (2nd pos) on left by special wrench and remove the cap

**!** It's recommended to fill with silicone oil type **DOW CORNING 200 FLUID cst 250 only.**

2nd – Fill the chamber (3rd pos) with oil, up to the end of thread as indicated with ("L" pos.).

3rd – Screw the cap (2nd pos) on right, oil exceeding will come out during this operation

-The hydraulic speed regulator is filled now, including the reserve tank.



## INSTRUCTIONS POUR LE REMPLISSAGE OU LE RETABLISSEMENT DU NIVEA D'HUILE

### RÉGULATEURS SÉRIES 25

1°- Dévisser dans le sens antihoraire le bouchon rep. 2 à l'aide d'une clef ou autre outil et l'enlever.

**!** Il est recommandé d'utiliser uniquement de l'huile siliconée du type **DOW CORNING 200 FLUID est 250.**

2°- Remplir d'huile la chambre rep.3 jusqu'au limite du filetage indiquée par la lettre « L ».

3°- Revisser le bouchon rep.2 en le tournant dans le sens horaire. L'huile en surplus sortira pendant le vissage.

Le régulateur est maintenant rechargé, y compris le réservoir de réserve.



## INSTRUCCIONES PARA CAMBIO O RELLENADO DE ACEITE

### REGULADORES SERIE 25

1°Deroscar el tapón roscado (2) en sentido antiorario mediante el uso de una llave adecuada y quitarlo.

**!** Se recomienda el uso exclusivo de aceite al silicone tipo **DOW CORNING 200FLUID est. 250.**

2° Rellenar con aceite la cámara contenedora (3) hasta del final de la zona interior roscada, indicada mediante la letra (L).

3° Roscar el tapón (2) en sentido horario. El aceite en exceso saldrá roscando el tapón de cierre.

El regulador de velocidad hidráulico esta lleno ahora, incluido su tanque de reserva.



# Regolatori idraulici di velocità – Serie 35 e Serie 40

## Hydraulic speed regulators – 35 and 40 series



### DESCRIZIONE

Costruzione a tiranti con serbatoio di compensazione in linea o in parallelo.

Il regolatore di velocità è un circuito idraulico chiuso, privo di una propria sorgente di potenza. Consiste praticamente di un cilindro riempito di olio, uno stelo con relativo pistone, una valvola di regolazione e un serbatoio di compensazione. Quando lo stelo del regolatore viene accoppiato ad un organo esterno in movimento il pistone del regolatore stesso si muove chiudendo la valvola unidirezionale interna quindi forzando l'olio attraverso il tubo di trasferimento verso la valvola di regolazione dove trova una restrizione variabile dall'esterno che ne determina la velocità. Dopo la valvola di regolazione l'olio fluisce nell'altra camera, separata tramite il pistone. Durante il movimento di ritorno la valvola unidirezionale si apre e l'olio fluisce senza ostacoli permettendo un rapido movimento di ritorno. Il serbatoio posto in linea o in parallelo ha la funzione di compensare la fuoriuscita e il livello dello stelo e compensare minimi trafilamenti. L'astina del serbatoio determina il livello d'olio. Su richiesta è possibile corredare questi regolatori di velocità con valvole di controllo: **valvole di accelerazione (SKIP) valvole di arresto (STOP), valvole di accelerazione e di arresto combinate (SKIP+STOP)**. Queste valvole sono normalmente aperte e vengono comandate ad aria. Così modificati i regolatori di velocità possono arrestare e/o accelerare la velocità prestabilita da un volantino regolabile dall'esterno.

### APPLICAZIONI

Il regolatore idraulico di velocità viene normalmente accoppiato ad un cilindro pneumatico onde ottenere una velocità costante del movimento.

### VELOCITA'

La velocità è regolabile.

**Le variazioni della temperatura provocano modifiche di viscosità dell'olio e quindi piccole variazioni di velocità.**

### CARATTERISTICHE COSTRUTTIVE

- Alesaggio.....	Diametro 35-40mm	- Pistone.....	Alluminio
- Testate.....	Alluminio ossidato nero	- Guarnizioni.....	NBR e poliuretano
- Stelo.....	Acciaio C45 cromato	- Valvole skip/stop.....	Alluminio ossidato nero
- Camicia.....	Acciaio trafilato lucido	- Olio.....	Idraulico, classe H simbolo ISO HG 46, viscosità 4,5 E. a 40° C
- Tiranti.....	Acciaio zincato		

### CARATTERISTICHE TECNICHE

-Carico max controllabile		-Velocità min e max.....	Senza valvole 70 – 10000 mm./min. Con valvole 0 – 6000 mm./min.
Serie 35.....	Senza valvole 400 Kgf. Con valvole 300 Kgf. (comprese inerzie di masse in movimento)	-Temperatura di esercizio.....	-10°C / +60°C
Serie 40.....	Senza valvole 600Kgf. Con valvole 500 Kgf. (comprese inerzie di masse in movimento)	-Press. azionamento valvole	Skip/Stop..... 4 – 8 bar



### DESCRIPTION

Tie rod construction with in-line or in-parallel compensation tank.

The speed regulator is basically a closed hydraulic circuit without its own power source. It consists of a cylinder filled with oil, a piston rod and piston, a control valve and a compensation tank. When the regulator rod couples with an external moving organ, the piston rod moves to close the one-way valve inside, which forces the oil through the transfer pipe towards the control valve, where it encounters a restriction that can be adjusted externally to determine the speed. The oil flows through the control valve into the other chamber which is separated by the piston. During return movement, the one-way valve opens and the oil flows freely to enable a rapid return movement. The in-line or in-parallel tank compensates the rod movement and minimum blow-by. The dip-stick in the tank can be used to determine the oil level. These speed regulators can be fitted with control valves as follows acceleration valves (SKIP), stop valves (STOP), acceleration + stop valve combinations (SKIP + STOP). These valves are normally opened and controlled by air. Modified in this way, speed regulators can stop and/or accelerate the speed set by an externally adjustable hand-wheel.

### APPLICATION

The hydraulic speed regulator is normally coupled with a pneumatic cylinder to get a constant speed.

### SPEED

The speed can be regulated

**Temperature variations alter the viscosity of the oil hence slightly affect the speed.**

### CONSTRUCTIVE CHARACTERISTICS

- Bore	35 mm and 40 mm diameter	- Piston	Aluminium
- Heads	Oxidized aluminium	- Gaskets	NBR and polyurethane
- Piston Rod	C45 chromium plated steel	- Skip/Stop Valves	Black oxidized aluminium
- Chamber	Drowned and polished steel	- Oil	Hydraulic, H class ISO symbol HG 46. 4,5 E. viscosity at 40°C
- Tie rods	Galvanized steel		

### TECHNICAL CHARACTERISTICS

- Maximum adjustable force		- Min. and max. speed	without valves: 70 – 10.000 mm./min. with valves: 0 – 6.000 mm./min.
Serie 35	without valves: 400 kgf. with valves: 300 kgf. (including any inertia developed by moving masses)	- Working temperature	- 10°C / +60°C
Serie 40	without valves: 600 kgf. with valves: 500 kgf. (including any inertia developed by moving masses)	- Pressure to act	Skip – Stop valves 4 – 8 bar

# Régulateurs hydrauliques de vitesse Séries 35 et 40

## Reguladores hidráulicos de velocidad Serie 35 y 40



### DESCRIPTION

Construction à tirants avec réservoir de compensation en ligne ou parallèle.

Un régulateur de vitesse est essentiellement un circuit hydraulique fermé dépourvu d'une source de puissance qui lui est propre. Il est constitué d'un cylindre rempli d'huile, d'un piston-tige, d'une soupape de réglage et d'un réservoir de compensation. Lorsque la tige du régulateur est accouplée à un organe extérieur mobile, le piston se met en mouvement et ferme une soupape unidirectionnelle située à l'intérieur. L'huile circule dans la vanne pointeau réglable. Le réglage détermine la vitesse. Après la vanne de réglage, l'huile s'écoule dans une autre chambre séparée par le piston. Pendant le mouvement de retour, la soupape unidirectionnelle s'ouvre et l'huile s'écoule sans obstacle, ce qui permet un mouvement de retour rapide. Le réservoir situé en ligne ou en parallèle a pour rôle de compenser la sortie et la rentrée de la tige ainsi que de légères fuites éventuelles. La jauge du réservoir détermine le niveau d'huile. Ces régulateurs peuvent être équipés, sur demande, de soupape de contrôle : **souppes d'accélération (SKIP), soupapes d'arrêt (STOP), soupapes combinées accélération + arrêt (SKIP + STOP)**. Ces soupapes sont normalement ouvertes, à commande pneumatique. Avec cette modification, les régulateurs de vitesse sont en mesure d'arrêter et/ou d'augmenter la vitesse prédéterminée par un bouton de réglage extérieur.

### APPLICATIONS

Le régulateur hydraulique de vitesse s'utilise habituellement accouplé à un vérin pneumatique pour obtenir une vitesse constante.

### VITESSE

Vitesse réglable.

**Les variations de température entraînent des changements de viscosité de l'huile, et donc légères variations de vitesse.**

### CARACTERISTIQUES DE CONSTRUCTION

- Alésage	Diamètre 35-40 mm.	- Piston	Aluminium
- Culasse	Aluminium oxydé noir	- Joints	NBR et Polyuréthane
- Tige	Acier C45 chromé	- Soupape Skip/Stop	Aluminium oxydé noir
- Chambre	Acier étiré et luisant	- Huile	Hydraulique, class H symbole ISO HG 46, visc. 4,5 E. à 40°C
- Ecrous	Acier zingué		

### CARACTERISTIQUES TECHNIQUES

- Charge max. contrôlable		- Vitesse min. et max.	sans soupapes 70 – 10000 mm/min. avec soupapes 0 – 6000 mm/min.
Série 35 : sans soupapes 300 kgf avec soupapes 400 kgf (y compris les inerties des masses en mouvement)		- Température de service	-10°C / + 60°C
Série 40 : sans soupapes 600 kgf avec soupapes 500 kgf (y compris les inerties des masses en mouvement)		- Pression actionnement des soupape Skip/Stop	4 – 8 bar



### DESCRIPCIÓN

Construcción con tirantes y compensador en línea o en paralelo.

El regulador de velocidad es un circuito hidráulico cerrado desprovisto de una fuente propia de potencia. Consiste en un cilindro llenado de aceite, un vástago y correspondiente embolo, una válvula de regulación y un tanque de compensación. Cuando el vástago del regulador es acoplado con un órgano externo en movimiento, el embolo de regulación se mueve, cerrando la válvula unidireccional interna y forzando así el aceite a través del tubo de paso hacia la válvula de regulación, donde encuentra un estrechamiento variable hacia el exterior que determina la velocidad. Pasada la válvula de regulación, el aceite fluye dentro de la otra cámara separada por medio del embolo. Durante el movimiento de regreso, la válvula unidireccional se abre y el aceite fluye sin obstáculos y permite el movimiento de regreso rápido. El tanque, colocado en línea o en paralelo, tiene la función de compensar la salida y el retorno del vástago y de compensar las pequeñas pérdidas. La varilla del tanque determina el nivel de aceite. Existe la posibilidad de dotar estos reguladores de velocidad con **válvulas de aceleración (SKIP), válvula de cierre (STOP), válvulas de aceleración y de cierre combinadas (SKIP+STOP)**. Estas válvulas están normalmente abiertas y son accionadas por aire. Así modificados, los reguladores de velocidad son aptos para detener y/o acelerar la velocidad preestablecida por un volante regulable desde el exterior.

### APLICACIONES

El regulador hidráulico de velocidad se acompla normalmente a un cilindro neumático para obtener una velocidad constante de movimiento.

### VELOCIDAD

La velocidad es regulable.

**Las variaciones de temperatura provocan cambios de viscosidad del aceite y por tanto, pequeñas variaciones de velocidad.**

### CARACTERÍSTICAS DE FABRICACION

- Diámetro interior	35 – 40 mm.	- Pistón	Alluminio
- Testera	Alluminio oxidado negro	- Juntas	NBR y poliuretano
- Barra	Acero C 45 cromado	- Válvulas STOP/SKIP	Alluminio oxidado negro
- Camisa	Acero trefilado brillante	- Aceite	Hidráulico, clase H, símbolo ISO HG 46, viscosidad 4,5 E. a 40°C
- Tirantes	Acero galvanizado		

### CARACTERÍSTICAS TÉCNICAS

- Carga máx. controlable		- Velocidad min. y máx.	sin válvulas 70 – 10000 mm/min. con válvulas 0 – 6000 mm/min.
Serie 35: sin válvulas: 400 Kgf. con válvulas: 300 Kgf. (incluidas inercias de masas en movimiento)		- Temperatura de trabajo	- 10°C + 60°C
Serie 40: sin válvulas: 600 Kgf. con válvulas: 500 Kgf. (incluidas inercias de masas en movimiento)		- Presión accionamiento valvulas Skip/Stop	4 – 8 bar.

# Regolatori idraulici di velocità - Hydraulic speed regulators

## Régulateurs hydrauliques de vitesse

## Reguladores hidráulicos de velocidad



### SERIE 35

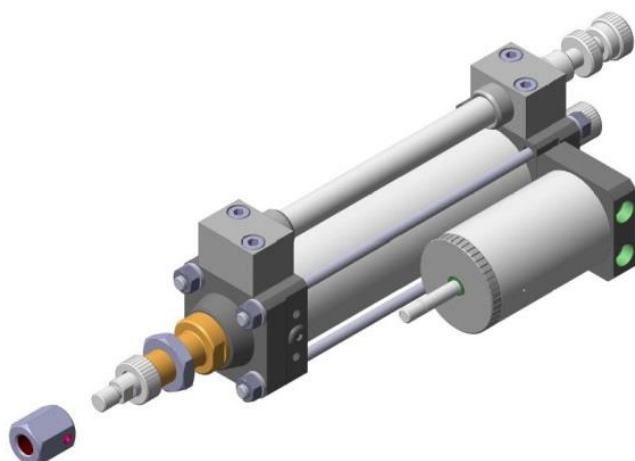

#### CHIAVE DI CODIFICA – KEY TO CODES

#### EXEMPLES DE CODIFICATION – EJEMPLOS DE CODIFICACIÓN

SERIE - SERIES SÉRIE - SERIE	SERBATOIO - TANK RÉSERVOIR - DEPÓSITO	REGOLAZIONE - REGULATION REGULATION - REGULACIÓN	CORSA - STROKE COURSE - CARRERA	TIPO VALVOLA - TYPE VALVE TYPE DE SOUPAPE - TIPO DE VÁLVULA	
<b>35</b>	<b>RL:</b> Serbatoio in linea In line tank Réservoir en ligne Depósito en línea  <b>RP:</b> Serbatoio in parallelo In-parallel tank Réservoir en parallèle Depósito en paralelo	<b>E:</b> Spinta (reg. rientro stelo) Thrust (piston rod return regulation) Poussée (régulation entrée de tige) Impulsión (regulación en entrada vástago)  <b>U:</b> Trazione (reg. uscita stelo) Traction (piston rod out regulation) Traction (régulation sortie de tige) Tracción (regulación en salida vástago)	<b>050 mm.</b> <b>100 mm.</b> <b>150 mm.</b> <b>200 mm.</b>  Corse speciali a richiesta Special stroke on demand Course spéciaux sur demande Carrera especial a pedido	<b>NO:</b> Senza valvola - Without valve Aucun Soupape - Sin válvula <b>VA:</b> Valvola SKIP - SKIP valve Soupape SKIP - Válvula de SKIP <b>AS:</b> Valvola SKIP + STOP - SKIP + STOP valve Soupape SKIP + ARRÊT Válvula de SKIP + STOP <b>VS:</b> Valvola STOP - STOP valve Soupape d'ARRÊT - Válvula de STOP <b>SP:</b> Speciale - Special - Spécial - Especial	<b>*C:</b> Valvola STOP normalmente chiusa  STOP valve normally closed  Soupape STOP normalement fermée  Válvula STOP normalmente cerrada

SERIE - SERIES SÉRIE - SERIE	SERBATOIO - TANK RÉSERVOIR - DEPÓSITO	REGOLAZIONE - REGULATION REGULATION - REGULACIÓN	CORSA - STROKE COURSE - CARRERA	TIPO VALVOLA - TYPE VALVE TYPE DE SOUPAPE - TIPO DE VÁLVULA	
<b>35</b>	<b>RP:</b> Serbatoio in parallelo In-parallel tank Réservoir en parallèle Depósito en paralelo	<b>D:</b> Doppia regolazione Dual regulation Double régulation Doble regulación	<b>050 mm.</b> <b>100 mm.</b> <b>150 mm.</b> <b>200 mm.</b>  Corse speciali a richiesta Special stroke on demand Course spéciaux sur demande Carrera especial a pedido	<b>NO:</b> Senza valvola - Without valve - Aucun Soupape - Sin válvula <b>SS:</b> Stop entrata/uscita - Stop in stroke/out stroke Soupape d'arrêt en entrée/sotie - Válvula de stop <b>SE:</b> Stop solo entrata - Stop in-stroke only Soupape d'arrêt en entrée - Válvula de stop entrata <b>SU:</b> Stop solo uscita - Stop out stroke only Soupape d'arrêt en sortie - Válvula de stop salida <b>AA:</b> Skip entrata/uscita - Skip in-stroke/out stroke Soupape de skip en entrée/sotie - Válvula de skip <b>AE:</b> Skip solo entrata - Skip in-stroke only Soupape de Skip en entrée - Válvula de skip entrata <b>AU:</b> Skip solo uscita - Skip out stroke only Soupape de Skip en sortie - Válvula de skip salida <b>SEAU:</b> Stop entrata/Skip uscita - Stop in-stroke / skip out-stroke Arrêt en entrée/Skip en sortie Válvula de stop entrata/skip salida <b>SUAE:</b> Stop uscita/Skip entrata - Stop out-stroke / skip in-stroke Arrêt en sortie/Skip en entrée Válvula de stop salida/skip entrata <b>ASAS:</b> Skip+Stop entrata/uscita - Skip+Stop in-stroke/out-stroke Skip+ Arrêt entrée/sortie - Válvula Skip+Stop entrata/salida	<b>*C:</b> Valvola STOP normalmente chiusa  STOP valve normally closed  Soupape STOP normalement fermée  Válvula STOP normalmente cerrada

\*A richiesta **valvola di STOP normalmente chiusa**. Aggiungere lettera "C"  
**STOP valve normally closed** on demand. Add reference "C"  
**Soupape STOP normalement fermée** sur demande. Ajouter référence "C"  
**Válvula STOP normalmente cerrada** a pedido. Agregar la letra "C"

**Serie 35 - Serbatoio in linea - Regolazione in uscita stelo**  
**35 serie - In line tank - Piston rod return regulation**  
**Séries 35 - Réservoir en ligne - Régulation sorti de tige**  
**Serie 35 - Depósito en línea - Regulación en salida vástago**



**35.RLU ... NO** Senza valvola - Without valve - Aucun Soupape - Sin válvula

DATI TECNICI E DIMENSIONI – SPECIFICATIONS AND DIMENSIONS  
 DONNÉES TECHNIQUES ET DIMENSIONS – DATOS TÉCNICO Y TAMAÑOS

MODELLO - MODEL MODÈLE - MODELO	CORSA - STROKE COURSE - CARRERA	Dimensioni – Dimensions Dimensions - Tamaños			
		A	B	L	U
<b>35.RLU.050.NO</b>	50	130	65	256	28
<b>35.RLU.100.NO</b>	100	180	65	306	28
<b>35.RLU.150.NO</b>	150	230	80	371	43
<b>35.RLU.200.NO</b>	200	280	80	421	43

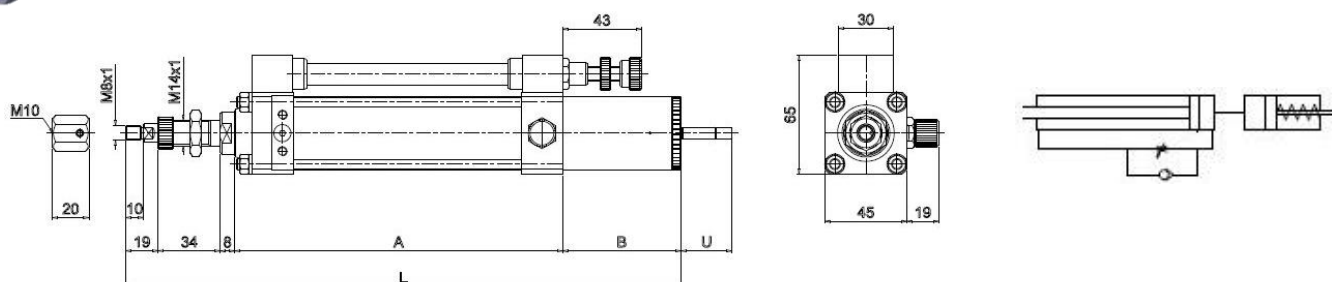
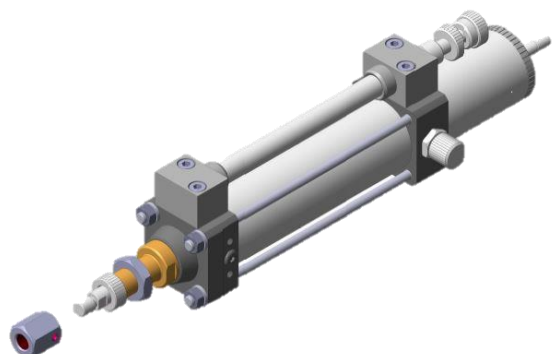

**35.RLU ... AS – ASC** Valvola SKIP + STOP - SKIP + STOP valve - Soupape SKIP + ARRET - Válvula de SKIP + STOP

DATI TECNICI E DIMENSIONI – SPECIFICATIONS AND DIMENSIONS  
 DONNÉES TECHNIQUES ET DIMENSIONS – DATOS TÉCNICO Y TAMAÑOS

MODELLO - MODEL MODÈLE - MODELO	CORSA - STROKE COURSE - CARRERA	Dimensioni – Dimensions Dimensions - Tamaños			
		A	B	L	U
<b>35.RLU.050.AS</b>	50	130	65	256	28
<b>35.RLU.100.AS</b>	100	180	65	306	28
<b>35.RLU.150.AS</b>	150	230	80	371	43
<b>35.RLU.200.AS</b>	200	280	80	421	43

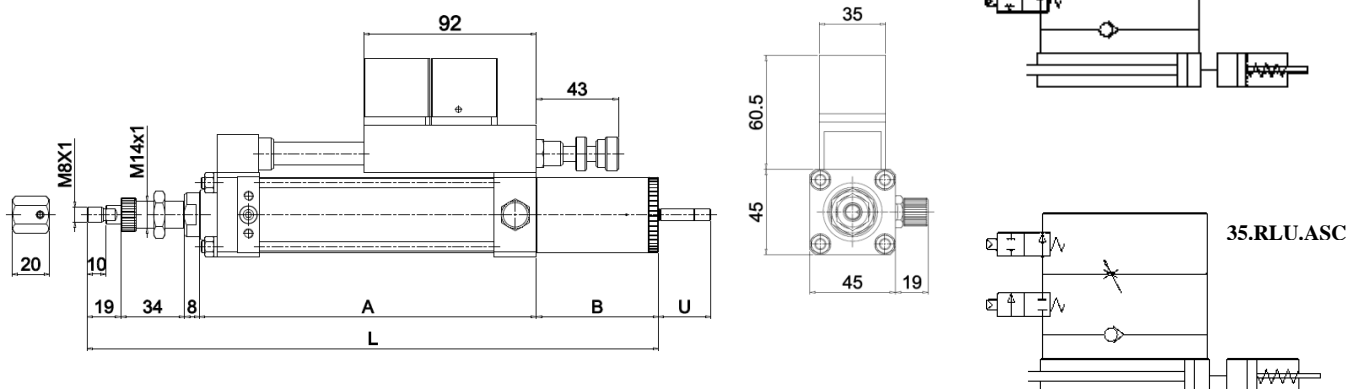
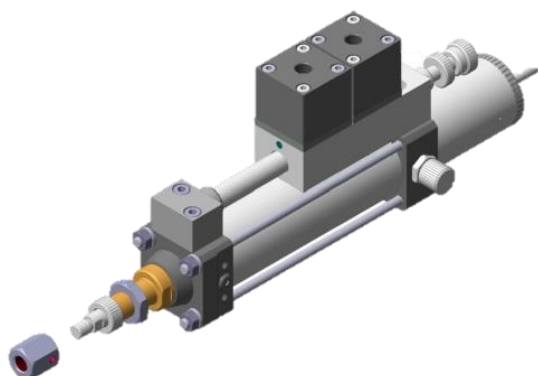

# Serie 35 - Serbatoio in linea - Regolazione in uscita stelo

## 35 serie - In line tank - Piston rod return regulation

### Séries 35 - Réservoir en ligne - Régulation sorti de tige

#### Serie 35 - Depósito en línea - Regulación en salida vástago



### 35.RLU ... VA

Valvola SKIP - SKIP valve - Soupape SKIP - Válvula de SKIP

DATI TECNICI E DIMENSIONI - SPECIFICATIONS AND DIMENSIONS  
 DONNÉES TECHNIQUES ET DIMENSIONS - DATOS TÉCNICO Y TAMAÑOS

MODELLO - MODEL MODÈLE - MODELO	CORSA - STROKE COURSE - CARRERA	Dimensioni - Dimensions Dimensions - Tamaños			
		A	B	L	U
35.RLU.050.VA	50	130	65	256	28
35.RLU.100.VA	100	180	65	306	28
35.RLU.150.VA	150	230	80	371	43
35.RLU.200.VA	200	280	80	421	43

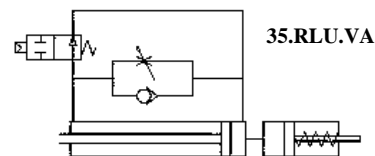
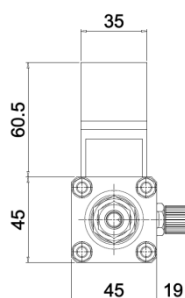
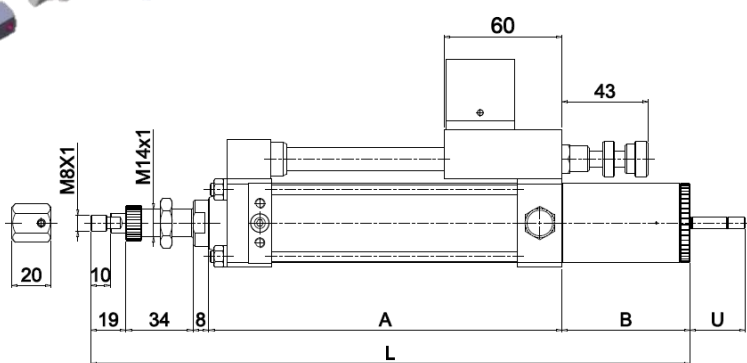
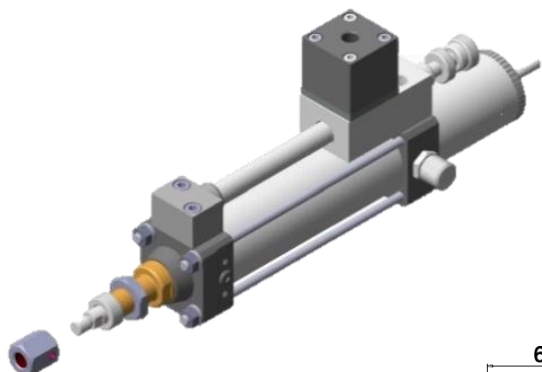

### 35.RLU ... VS - VSC

Valvola STOP - STOP valve - Soupape d'ARRÊT - Válvula de STOP

DATI TECNICI E DIMENSIONI - SPECIFICATIONS AND DIMENSIONS  
 DONNÉES TECHNIQUES ET DIMENSIONS - DATOS TÉCNICO Y TAMAÑOS

MODELLO - MODEL MODÈLE - MODELO	CORSA - STROKE COURSE - CARRERA	Dimensioni - Dimensions Dimensions - Tamaños			
		A	B	L	U
35.RLU.050.VS	50	130	65	256	28
35.RLU.100.VS	100	180	65	306	28
35.RLU.150.VS	150	230	80	371	43
35.RLU.200.VS	200	280	80	421	43

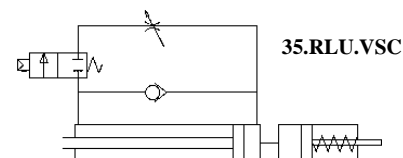
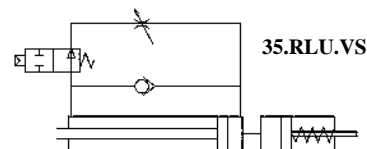
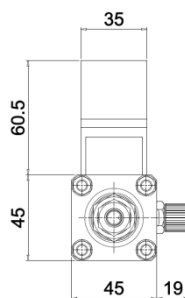
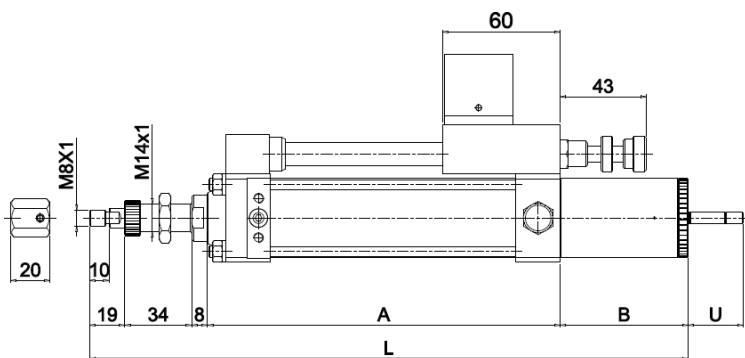
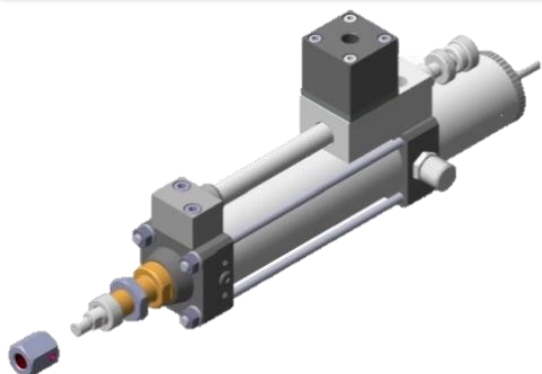

# Serie 35 - Serbatoio inparallelo - Regolazione in uscita stelo

## 35 serie - In-parallel tank- Piston rod return regulation

### Séries 35 - Réservoir en parallèle - Régulation sorti de tige

### Serie 35 - Depósito en paralelo - Regulación en salida vástago



### 35.RPU ... NO

Senza valvola - Without valve - Aucun Soupape - Sin válvula

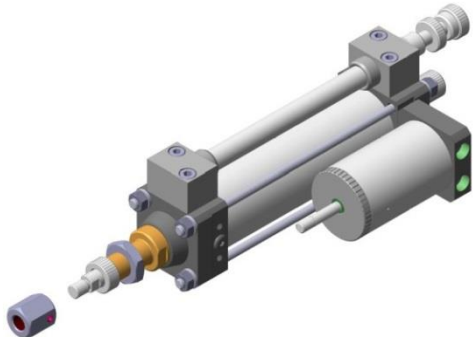

DATI TECNICI E DIMENSIONI - SPECIFICATIONS AND DIMENSIONS  
 DONNÉES TECHNIQUES ET DIMENSIONS - DATOS TÉCNICO Y TAMAÑOS

MODELLO - MODEL MODÈLE - MODELO	CORSA - STROKE COURSE - CARRERA	Dimensioni - Dimensions Dimensions - Tamaños			
		A	B	L	U
35.RPU.050.NO	50	139	98	200	28
35.RPU.100.NO	100	189	98	250	28
35.RPU.150.NO	150	239	113	300	43
35.RPU.200.NO	200	289	113	350	43

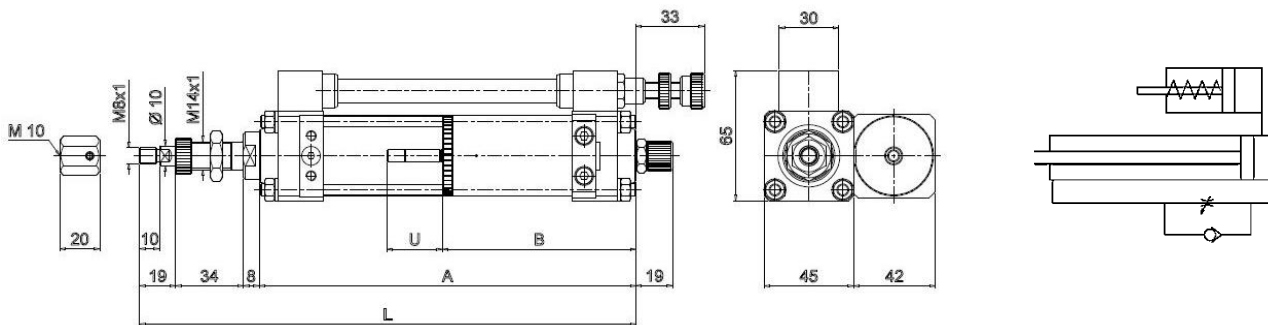

### 35.RPU ... AS - ASC

Valvola SKIP + STOP - SKIP + STOP valve - Soupape SKIP + ARRET - Válvula de SKIP + STOP

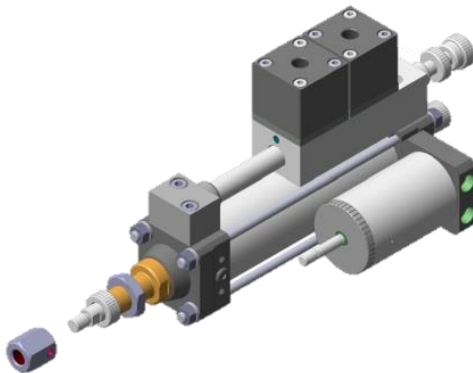

DATI TECNICI E DIMENSIONI - SPECIFICATIONS AND DIMENSIONS  
 DONNÉES TECHNIQUES ET DIMENSIONS - DATOS TÉCNICO Y TAMAÑOS

MODELLO - MODEL MODÈLE - MODELO	CORSA - STROKE COURSE - CARRERA	Dimensioni - Dimensions Dimensions - Tamaños			
		A	B	L	U
35.RPU.050.AS	50	139	98	200	28
35.RPU.100.AS	100	189	98	250	28
35.RPU.150.AS	150	239	113	300	43
35.RPU.200.AS	200	289	113	350	43

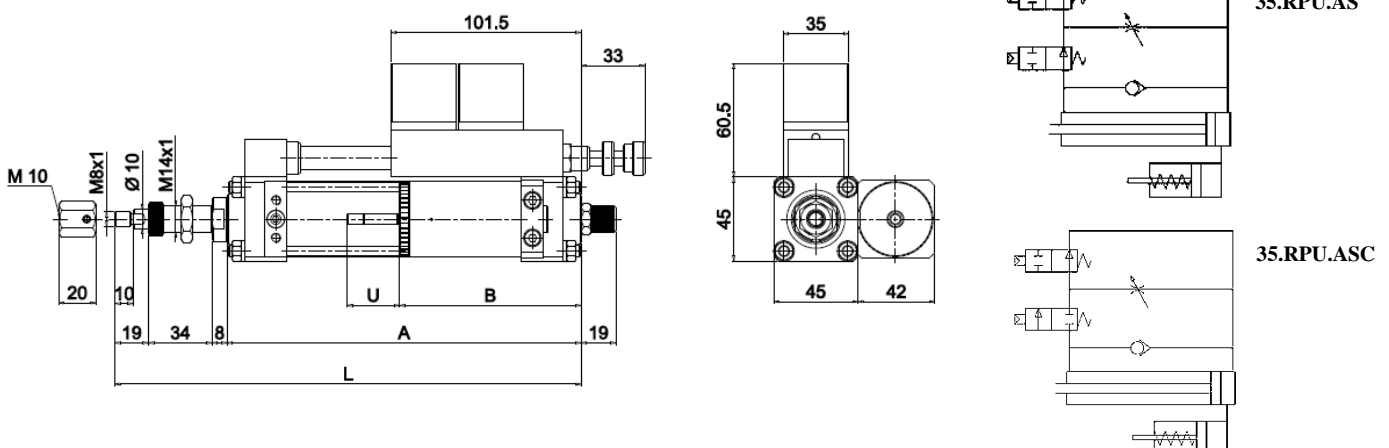

# Serie 35 - Serbatoio inparallelo - Regolazione in uscita stelo

# 35 serie - In-parallel tank- Piston rod return regulation

# Séries 35 - Réservoir en parallèle - Régulation sorti de tige

# Serie 35 - Depósito en paralelo - Regulación en salida vástago



## 35.RPU ... VA Valvola SKIP - SKIP valve - Soupape SKIP - Válvula de SKIP

DATI TECNICI E DIMENSIONI – SPECIFICATIONS AND DIMENSIONS  
 DONNÉES TECHNIQUES ET DIMENSIONS – DATOS TÉCNICO Y TAMAÑOS

MODELLO - MODEL MODÈLE - MODELO	CORSA - STROKE COURSE - CARRERA	Dimensioni – Dimensions Dimensions - Tamaños			
		A	B	L	U
35.RPU.050.VA	50	139	98	200	28
35.RPU.100.VA	100	189	98	250	
35.RPU.150.VA	150	239	113	300	43
35.RPU.200.VA	200	289	113	350	

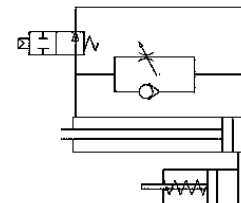
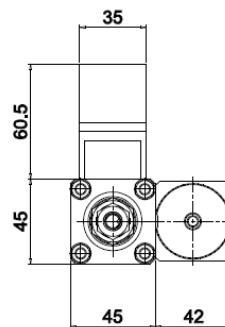
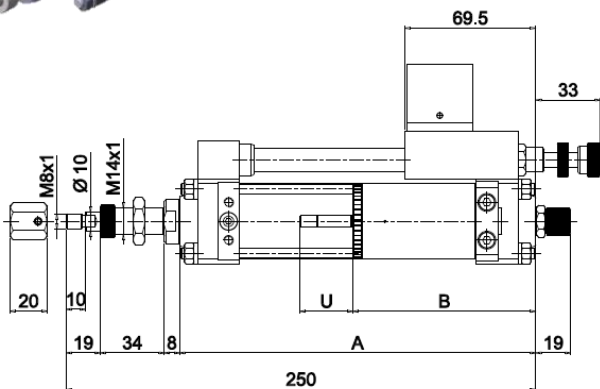
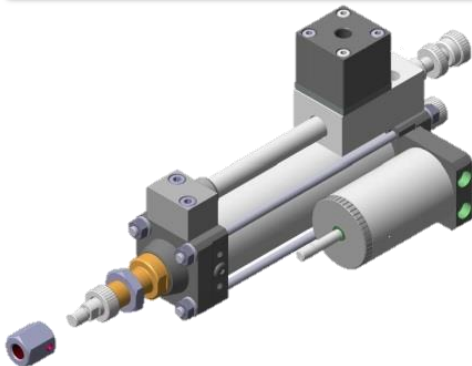

## 35.RPU ... VS – VSC Valvola STOP - STOP valve - Soupape d'ARRÊT - Válvula de STOP

DATI TECNICI E DIMENSIONI – SPECIFICATIONS AND DIMENSIONS  
 DONNÉES TECHNIQUES ET DIMENSIONS – DATOS TÉCNICO Y TAMAÑOS

MODELLO - MODEL MODÈLE - MODELO	CORSA - STROKE COURSE - CARRERA	Dimensioni – Dimensions Dimensions - Tamaños			
		A	B	L	U
35.RPU.050.VS	50	139	98	200	28
35.RPU.100.VS	100	189	98	250	
35.RPU.150.VS	150	239	113	300	43
35.RPU.200.VS	200	289	113	350	

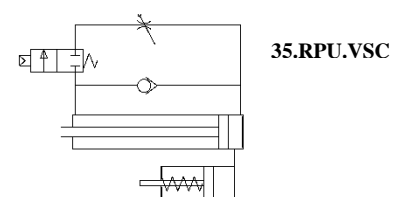
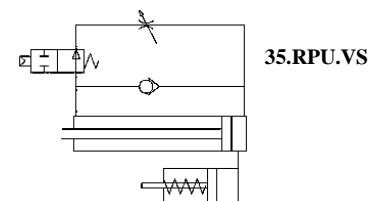
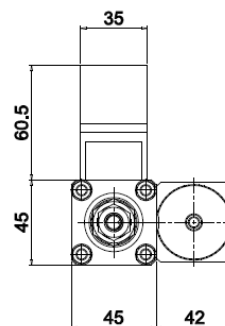
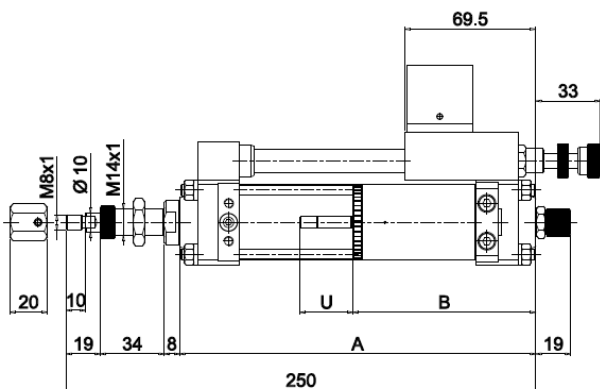
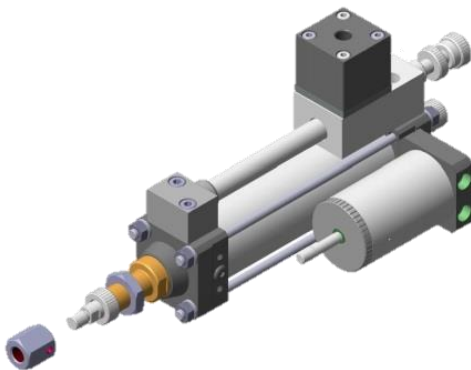

# Serie 35 - Serbatoio in parallelo - Regolazione in entrata stelo

## 35 serie - In-parallel tank- Piston rod return regulation

### Séries 35 - Réservoir en parallèle - Régulation entrée de tige

#### Serie 35 - Depósito en paralelo - Regulación en entrada vástago



### 35.RPE ... NO

Senza valvola - Without valve - Aucun Soupape - Sin válvula

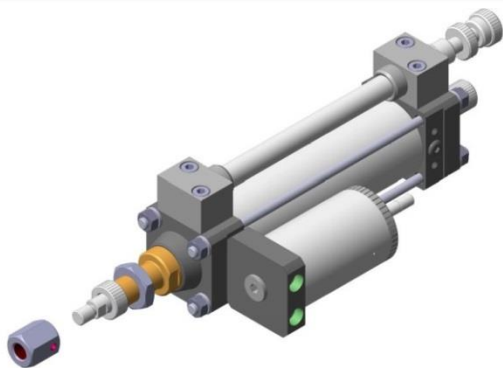

DATI TECNICI E DIMENSIONI - SPECIFICATIONS AND DIMENSIONS  
DONNÉES TECHNIQUES ET DIMENSIONS - DATOS TÉCNICO Y TAMAÑOS

MODELLO - MODEL MODÈLE - MODELO	CORSA - STROKE COURSE - CARRERA	Dimensioni - Dimensions Dimensions - Tamaños			
		A	B	L	U
35.RPE.050.NO	50	139	98	200	28
35.RPE.100.NO	100	189	98	250	28
35.RPE.150.NO	150	239	113	300	43
35.RPE.200.NO	200	289	113	350	43

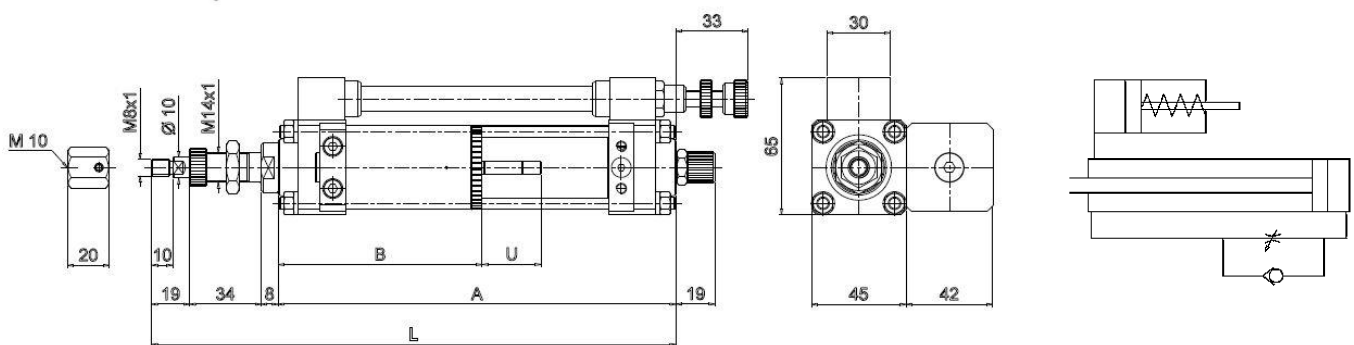

### 35.RPE ... AS - ASC

Valvola SKIP + STOP - SKIP + STOP valve - Soupape SKIP + ARRET - Válvula de SKIP + STOP

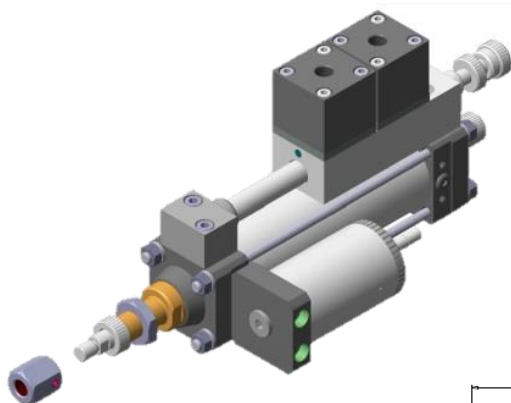

DATI TECNICI E DIMENSIONI - SPECIFICATIONS AND DIMENSIONS  
DONNÉES TECHNIQUES ET DIMENSIONS - DATOS TÉCNICO Y TAMAÑOS

MODELLO - MODEL MODÈLE - MODELO	CORSA - STROKE COURSE - CARRERA	Dimensioni - Dimensions Dimensions - Tamaños			
		A	B	L	U
35.RPE.050.AS	50	139	98	200	28
35.RPE.100.AS	100	189	98	250	28
35.RPE.150.AS	150	239	113	300	43
35.RPE.200.AS	200	289	113	350	43

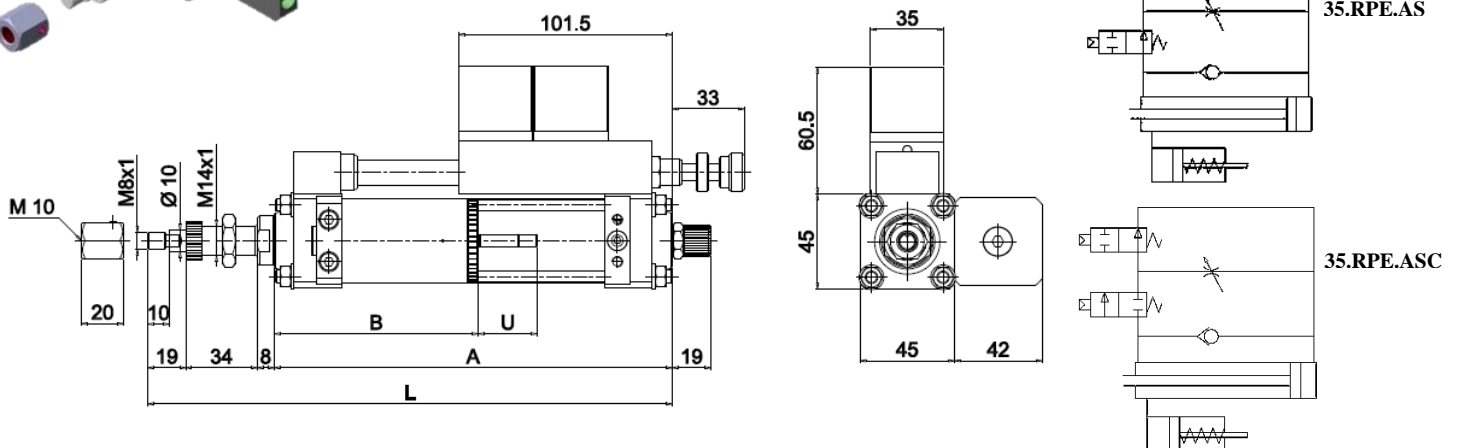



# Serie 35 - Serbatoio in parallelo - Regolazione in entrata stelo

## 35 serie - In-parallel tank- Piston rod return regulation

### Séries 35 - Réservoir en parallèle - Régulation entrée de tige

#### Serie 35 - Depósito en paralelo - Regulación en entrada vástago



### 35.RPE ... VA

Valvola SKIP - SKIP valve - Soupape SKIP - Válvula de SKIP

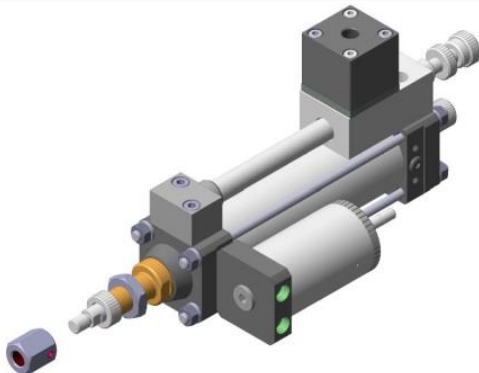

DATI TECNICI E DIMENSIONI – SPECIFICATIONS AND DIMENSIONS  
 DONNÉES TECHNIQUES ET DIMENSIONS – DATOS TÉCNICO Y TAMAÑOS

MODELLO - MODEL MODÈLE - MODELO	CORSA - STROKE COURSE - CARRERA	Dimensioni - Dimensions Dimensions - Tamaños			
		A	B	L	U
35.RPE.050.VA	50	139	98	200	28
35.RPE.100.VA	100	189	98	250	28
35.RPE.150.VA	150	239	113	300	43
35.RPE.200.VA	200	289	113	350	43

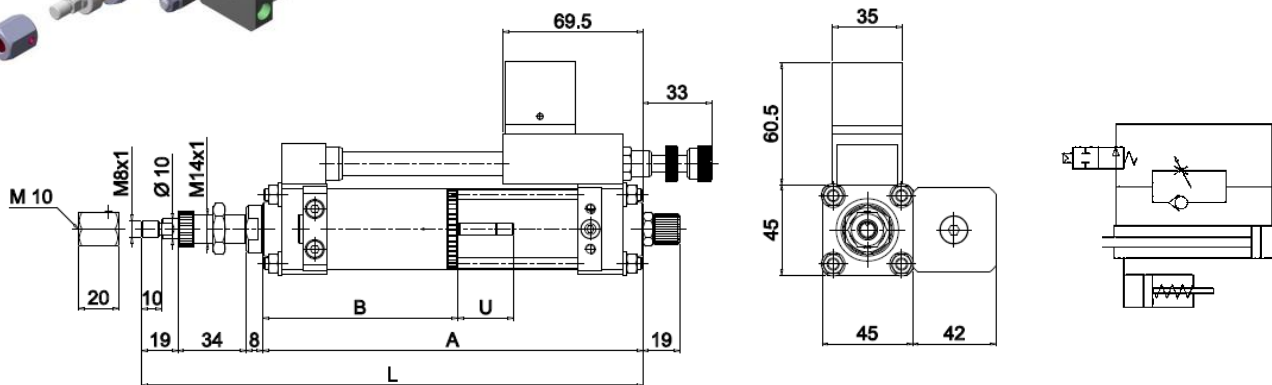

### 35.RPE ... VS – VSC

Valvola STOP - STOP valve - Soupape d'ARRÊT - Válvula de STOP

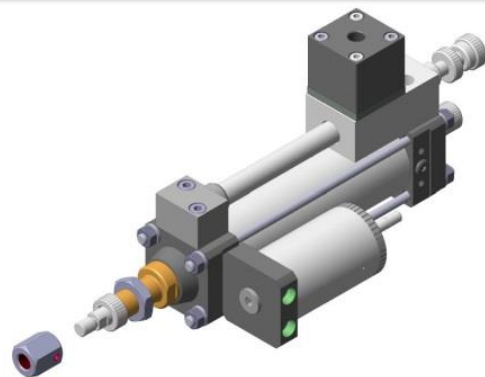

DATI TECNICI E DIMENSIONI – SPECIFICATIONS AND DIMENSIONS  
 DONNÉES TECHNIQUES ET DIMENSIONS – DATOS TÉCNICO Y TAMAÑOS

MODELLO - MODEL MODÈLE - MODELO	CORSA - STROKE COURSE - CARRERA	Dimensioni - Dimensions Dimensions - Tamaños			
		A	B	L	U
35.RPE.050.VS	50	139	98	200	28
35.RPE.100.VS	100	189	98	250	28
35.RPE.150.VS	150	239	113	300	43
35.RPE.200.VS	200	289	113	350	43

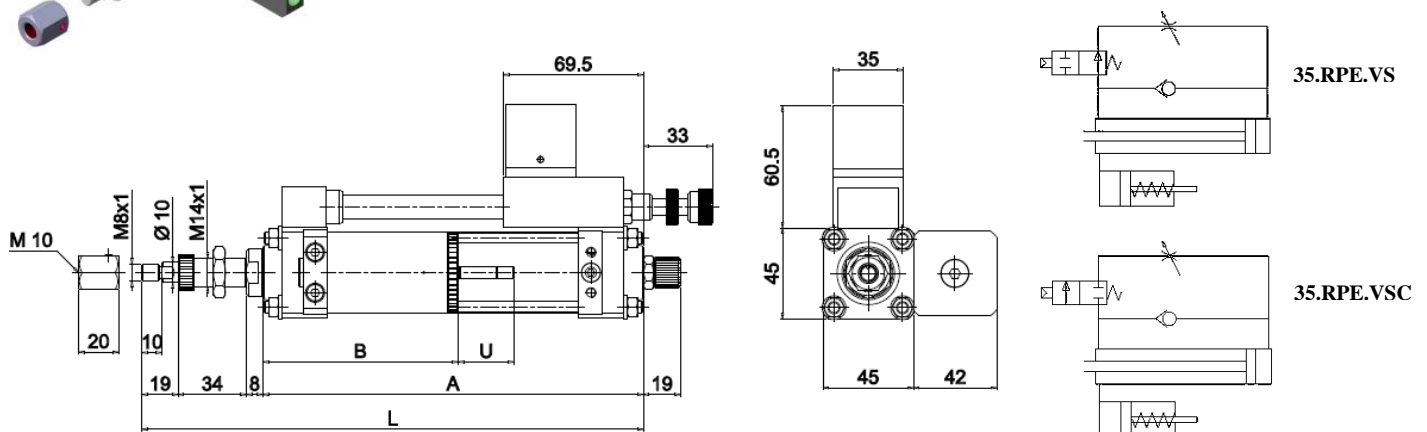

Serie 35 - Serbatoio in parallelo - Doppia regolazione  
 35 serie - In-parallel tank- Dual regulation

Séries 35 - Réservoir en parallèle - Double régulation

Serie 35 - Depósito en paralelo - Doble regulación



**35.RPD ... NO**

Senza valvola - Without valve - Aucun Soupape - Sin válvula

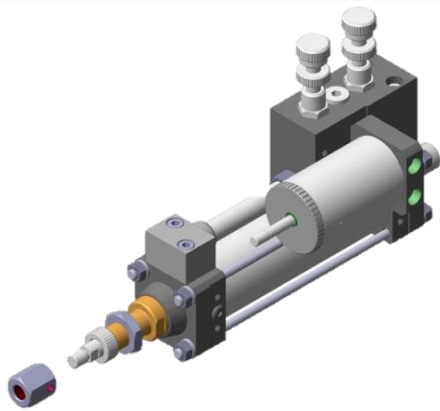

DATI TECNICI E DIMENSIONI - SPECIFICATIONS AND DIMENSIONS  
 DONNÉES TECHNIQUES ET DIMENSIONS - DATOS TÉCNICO Y TAMAÑOS

MODELLO - MODEL MODÈLE - MODELO	CORSA - STROKE COURSE - CARRERA	Dimensioni - Dimensions Dimensions - Tamaños			
		A	B	L	U
35.RPD.050.NO	50	139	125	200	28
35.RPD.100.NO	100	189	125	250	28
35.RPD.150.NO	150	239	140	300	43
35.RPD.200.NO	200	289	140	350	43

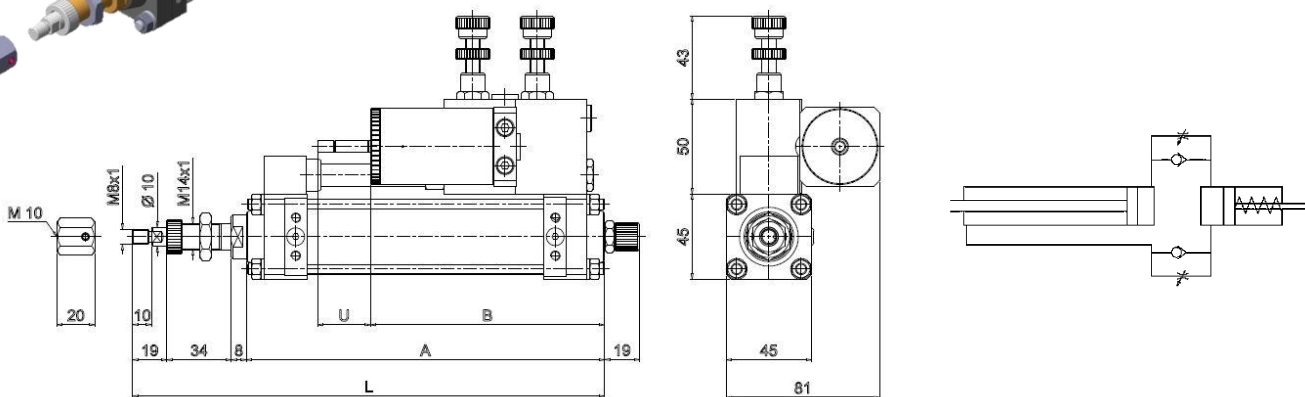

**35.RPD ... AA**

Skip entrata/uscita - Skip in-stroke/out stroke - Soupape de skip en entrée/sotie - Válvula de skip

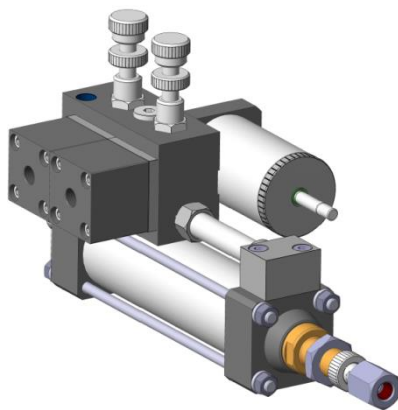

DATI TECNICI E DIMENSIONI - SPECIFICATIONS AND DIMENSIONS  
 DONNÉES TECHNIQUES ET DIMENSIONS - DATOS TÉCNICO Y TAMAÑOS

MODELLO - MODEL MODÈLE - MODELO	CORSA - STROKE COURSE - CARRERA	Dimensioni - Dimensions Dimensions - Tamaños			
		A	B	L	U
35.RPD.050.AA	50	139	125	200	28
35.RPD.100.AA	100	189	125	250	28
35.RPD.150.AA	150	239	140	300	43
35.RPD.200.AA	200	289	140	350	43

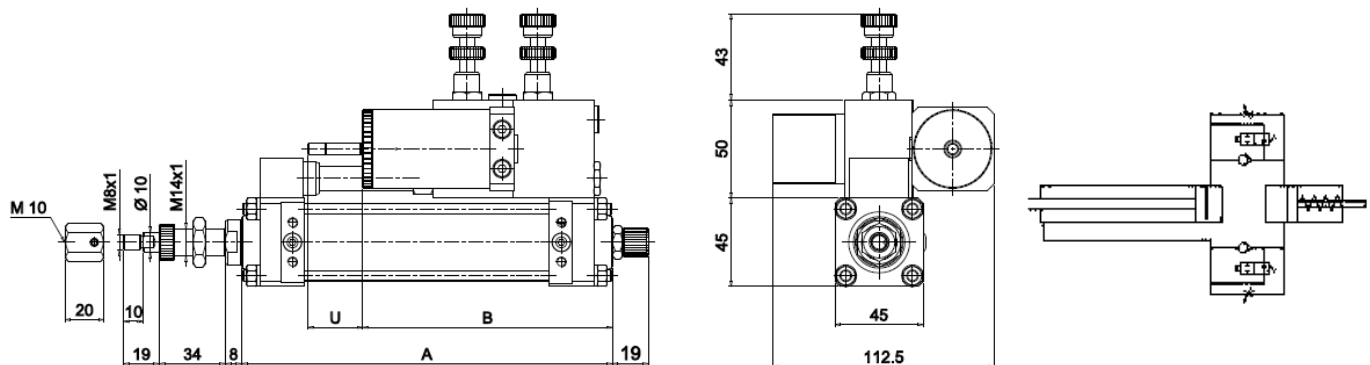

Serie 35 - Serbatoio in parallelo - Doppia regolazione  
 35 serie - In-parallel tank- Dual regulation

Séries 35 - Réservoir en parallèle - Double régulation

Serie 35 - Depósito en paralelo - Doble regulación



**35.RPD ... AE** Skip solo entrata - Skip in-stroke only

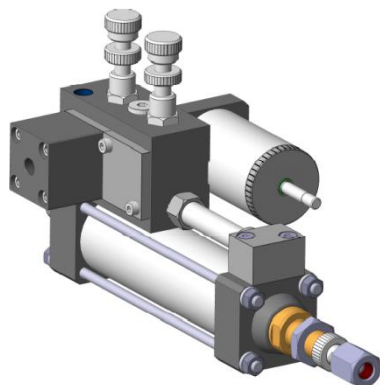

DATI TECNICI E DIMENSIONI - SPECIFICATIONS AND DIMENSIONS  
 DONNÉES TECHNIQUES ET DIMENSIONS - DATOS TÉCNICO Y TAMAÑOS

MODELLO - MODEL MODÈLE - MODELO	CORSA - STROKE COURSE - CARRERA	Dimensioni - Dimensions Dimensions - Tamaños			
		A	B	L	U
<b>35.RPD.050.AE</b>	50	139	125	200	28
<b>35.RPD.100.AE</b>	100	189	125	250	28
<b>35.RPD.150.AE</b>	150	239	140	300	43
<b>35.RPD.200.AE</b>	200	289	140	350	43

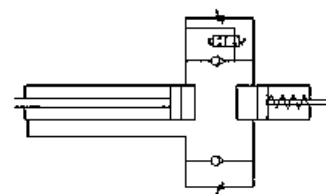
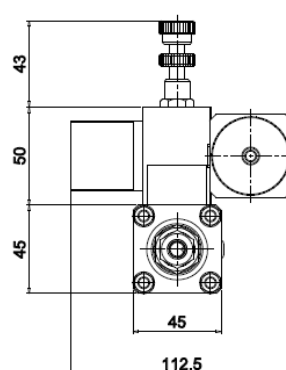
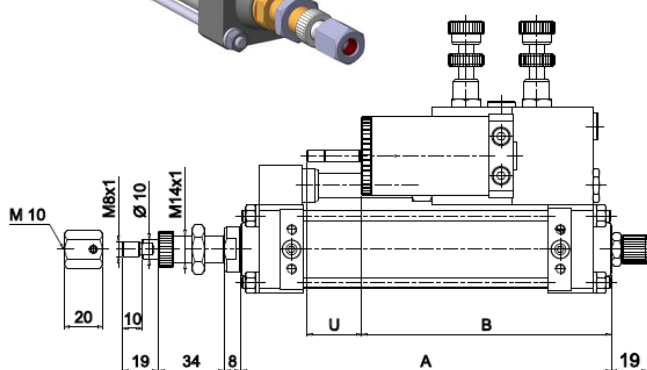

**35.RPD ... AU** Skip solo uscita - Skip out stroke only - Soupape de Skip en sortie - Válvula de skip salida

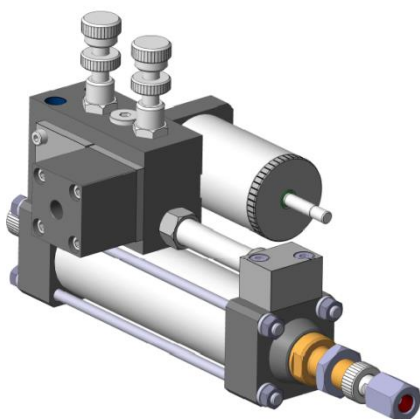

DATI TECNICI E DIMENSIONI - SPECIFICATIONS AND DIMENSIONS  
 DONNÉES TECHNIQUES ET DIMENSIONS - DATOS TÉCNICO Y TAMAÑOS

MODELLO - MODEL MODÈLE - MODELO	CORSA - STROKE COURSE - CARRERA	Dimensioni - Dimensions Dimensions - Tamaños			
		A	B	L	U
<b>35.RPD.050.AU</b>	50	139	125	200	28
<b>35.RPD.100.AU</b>	100	189	125	250	28
<b>35.RPD.150.AU</b>	150	239	140	300	43
<b>35.RPD.200.AU</b>	200	289	140	350	43

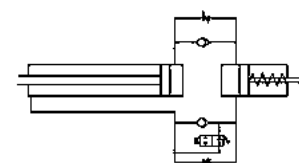
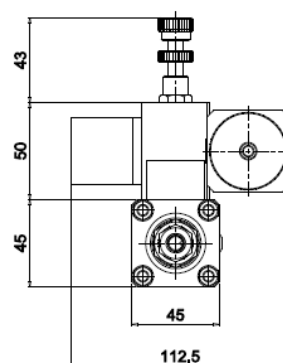
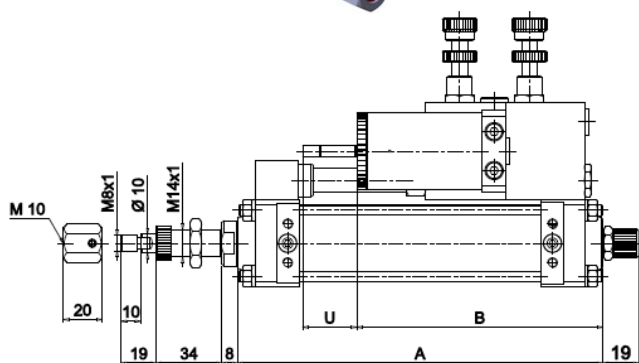

Serie 35 - Serbatoio in parallelo - Doppia regolazione  
 35 serie - In-parallel tank- Dual regulation

Séries 35 - Réservoir en parallèle - Double régulation

Serie 35 - Depósito en paralelo - Doble regulación



**35.RPD ... SS - SSC** Stop entrata/uscita – Stop in stroke/out stroke - Soupape d'arrêt en entrée/sotie – Válvula de stop

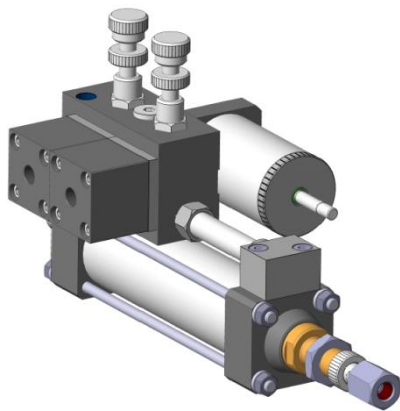

DATI TECNICI E DIMENSIONI – SPECIFICATIONS AND DIMENSIONS  
 DONNÉES TECHNIQUES ET DIMENSIONS – DATOS TÉCNICO Y TAMAÑOS

MODELLO - MODEL MODÈLE - MODELO	CORSA - STROKE COURSE - CARRERA	Dimensioni – Dimensions Dimensions - Tamaños			
		A	B	L	U
35.RPD.050.SS	50	139	125	200	28
35.RPD.100.SS	100	189	125	250	28
35.RPD.150.SS	150	239	140	300	43
35.RPD.200.SS	200	289	140	350	43

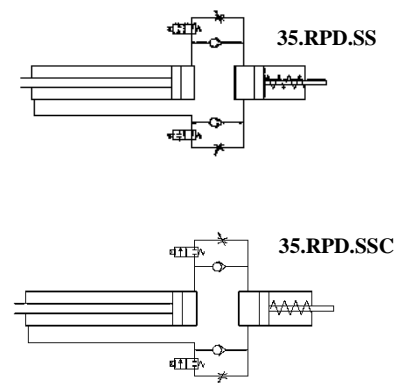
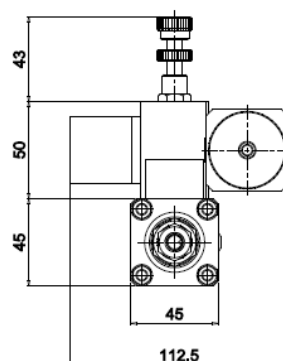
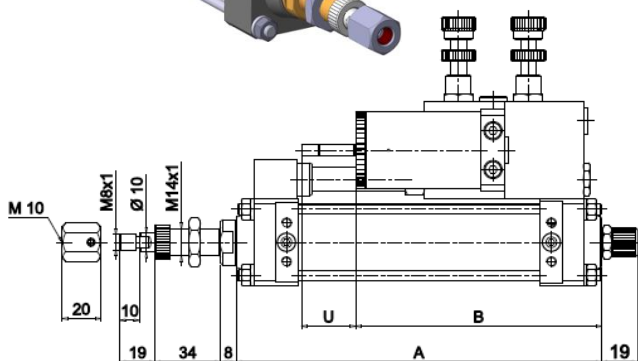

**35.RPD ... SE - SEC** Stop solo entrata – Stop in-stroke only - Soupape d'arrêt en entrée - Válvula de stop entrada

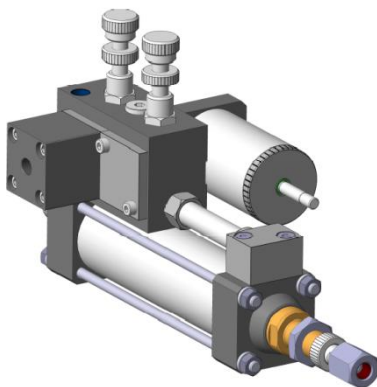

DATI TECNICI E DIMENSIONI – SPECIFICATIONS AND DIMENSIONS  
 DONNÉES TECHNIQUES ET DIMENSIONS – DATOS TÉCNICO Y TAMAÑOS

MODELLO - MODEL MODÈLE - MODELO	CORSA - STROKE COURSE - CARRERA	Dimensioni – Dimensions Dimensions - Tamaños			
		A	B	L	U
35.RPD.050.SE	50	139	125	200	28
35.RPD.100.SE	100	189	125	250	28
35.RPD.150.SE	150	239	140	300	43
35.RPD.200.SE	200	289	140	350	43

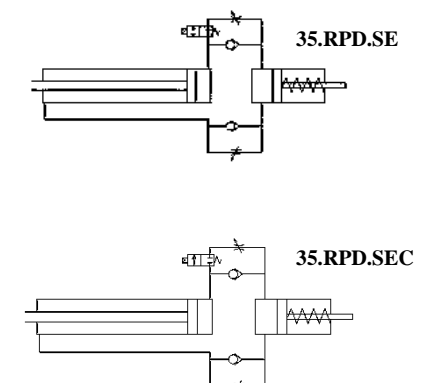
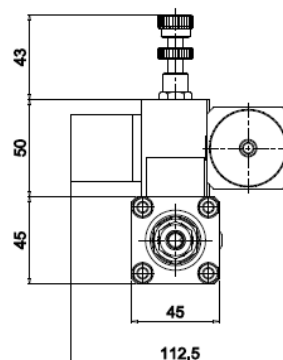
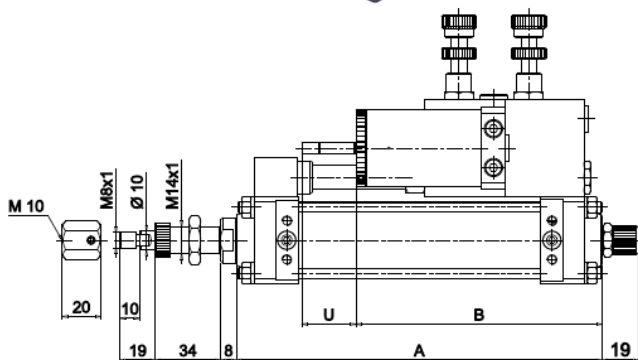

Serie 35 - Serbatoio in parallelo - Doppia regolazione  
 35 serie - In-parallel tank- Dual regulation

Séries 35 - Réservoir en parallèle - Double régulation

Serie 35 - Depósito en paralelo - Doble regulación



**35.RPD ... SU - SUC** Stop solo uscita – Stop out stroke only - Soupape d'arrêt en sortie - Válvula de stop salida

DATI TECNICI E DIMENSIONI – SPECIFICATIONS AND DIMENSIONS  
 DONNÉES TECHNIQUES ET DIMENSIONS – DATOS TÉCNICO Y TAMAÑOS

MODELLO - MODEL MODÈLE - MODELO	CORSA - STROKE COURSE - CARRERA	Dimensioni – Dimensions Dimensions - Tamaños			
		A	B	L	U
35.RPD.050.SU	50	139	125	200	28
35.RPD.100.SU	100	189		250	
35.RPD.150.SU	150	239	140	300	43
35.RPD.200.SU	200	289		350	

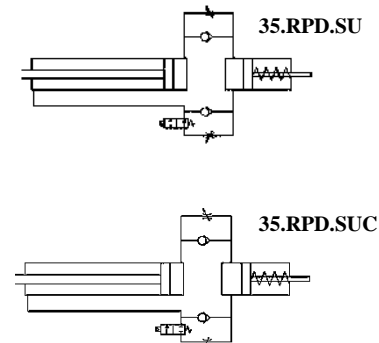
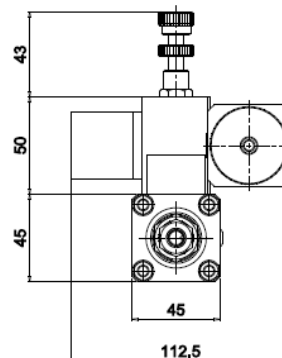
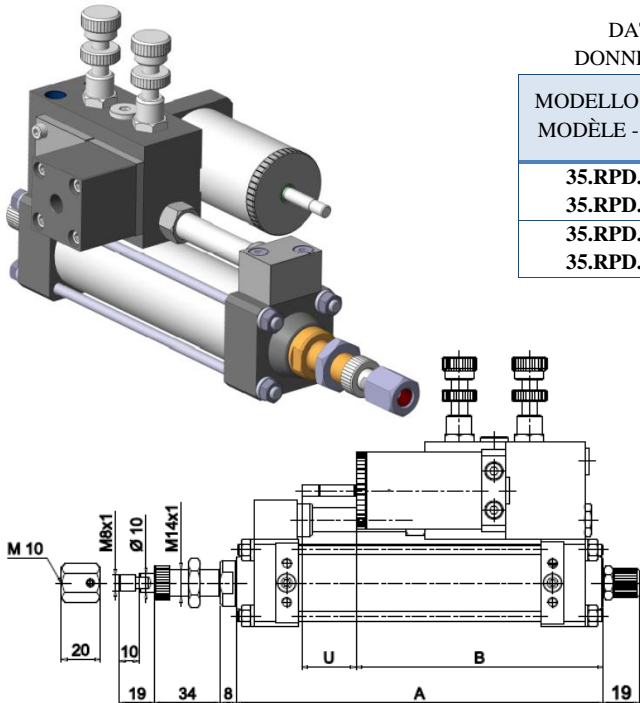

**35.RPD ... SEAU - SEAU** Stop entrata/Skip uscita – Stop in-stroke / skip out-stroke -  
 Arrêt en entrée/Skip en sortie - Válvula de stop entrada/skip salida

DATI TECNICI E DIMENSIONI – SPECIFICATIONS AND DIMENSIONS  
 DONNÉES TECHNIQUES ET DIMENSIONS – DATOS TÉCNICO Y TAMAÑOS

MODELLO - MODEL MODÈLE - MODELO	CORSA - STROKE COURSE - CARRERA	Dimensioni – Dimensions Dimensions - Tamaños			
		A	B	L	U
35.RPD.050.SEAU	50	139	125	200	28
35.RPD.100.SEAU	100	189		250	
35.RPD.150.SEAU	150	239	140	300	43
35.RPD.200.SEAU	200	289		350	

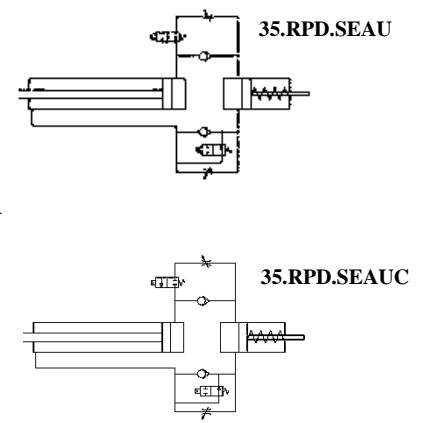
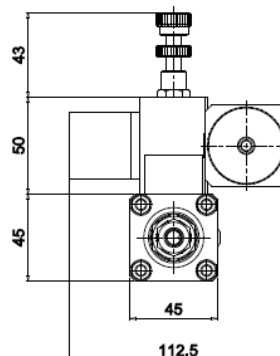
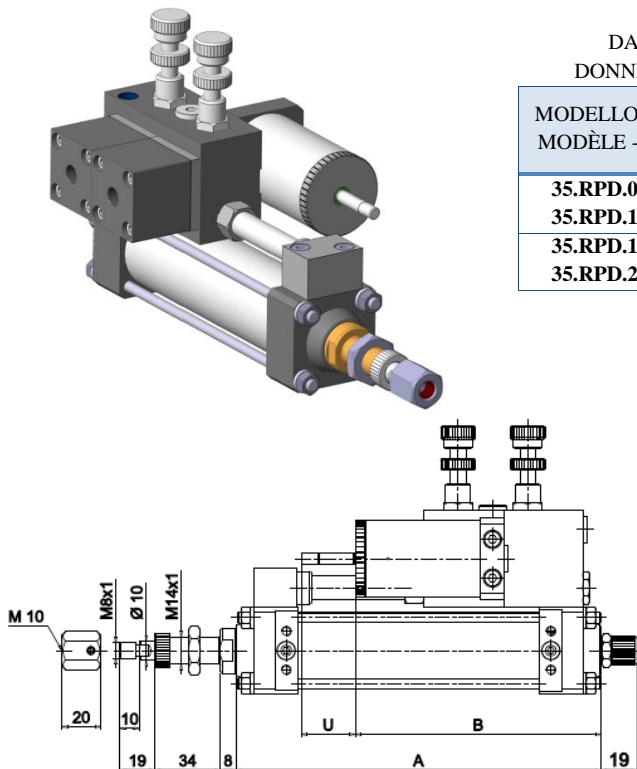

# Serie 35 - Serbatoio in parallelo - Doppia regolazione

## 35 serie - In-parallel tank- Dual regulation

## Séries 35 - Réservoir en parallèle - Double régulation

## Serie 35 - Depósito en paralelo - Doble regulación



### 35.RPD ... SUAEC - SUAEC

Stop uscita/Skip entrata - Stop out-stroke / skip in-stroke  
 Arrêt en sortie/Skip en entrée - Válvula de stop salida/skip entrada

DATI TECNICI E DIMENSIONI - SPECIFICATIONS AND DIMENSIONS  
 DONNÉES TECHNIQUES ET DIMENSIONS - DATOS TÉCNICO Y TAMAÑOS

MODELLO - MODEL MODÈLE - MODELO	CORSA - STROKE COURSE - CARRERA	Dimensioni - Dimensions Dimensions - Tamaños			
		A	B	L	U
35.RPD.050.SUAEC	50	139	125	200	28
35.RPD.100.SUAEC	100	189	125	250	28
35.RPD.150.SUAEC	150	239	140	300	43
35.RPD.200.SUAEC	200	289	140	350	43

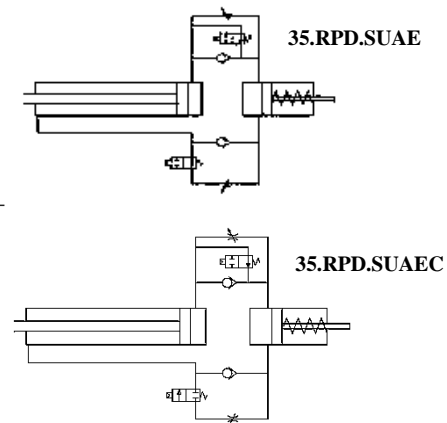
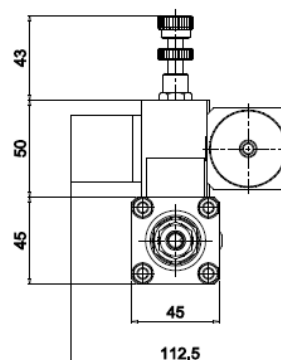
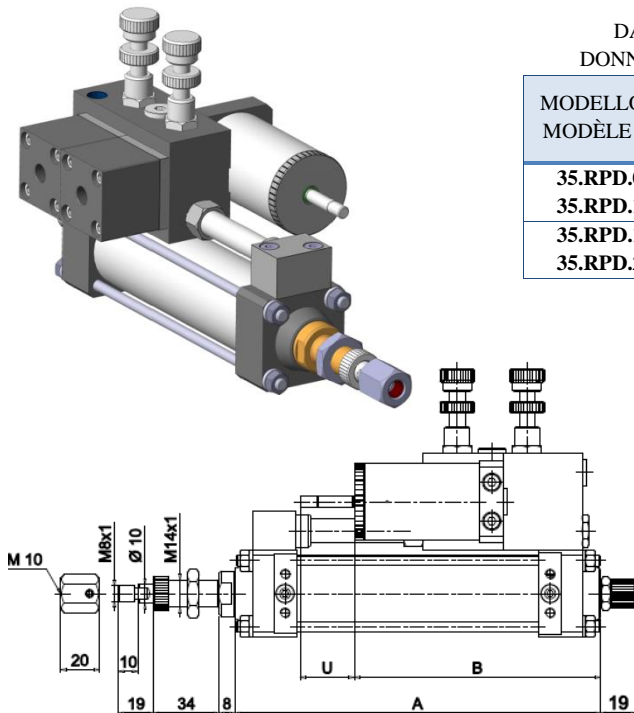

### 35.RPD ... ASAS - ASASC

Skip+Stop entrata/uscita - Skip+Stop in-stroke/out-stroke  
 Skip+ Arrêt entrée/sortie - Válvula Skip+Stop entrada/salida

DATI TECNICI E DIMENSIONI - SPECIFICATIONS AND DIMENSIONS  
 DONNÉES TECHNIQUES ET DIMENSIONS - DATOS TÉCNICO Y TAMAÑOS

MODELLO - MODEL MODÈLE - MODELO	CORSA - STROKE COURSE - CARRERA	Dimensioni - Dimensions Dimensions - Tamaños			
		A	B	L	U
35.RPD.150.ASAS	150	239	140	300	43
35.RPD.200.ASAS	200	289	140	350	43

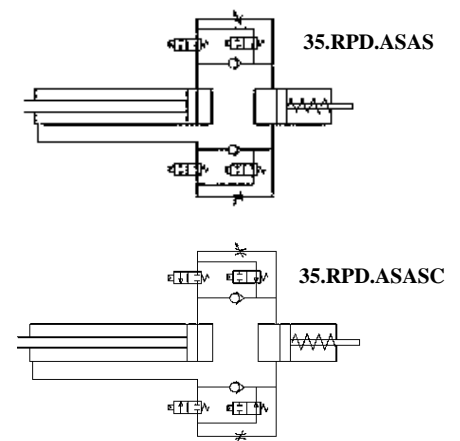
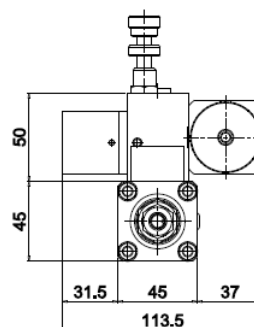
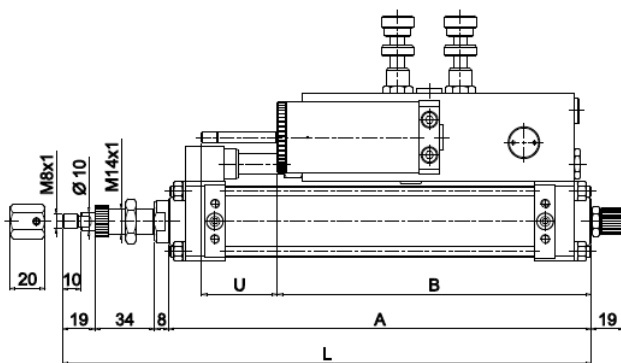
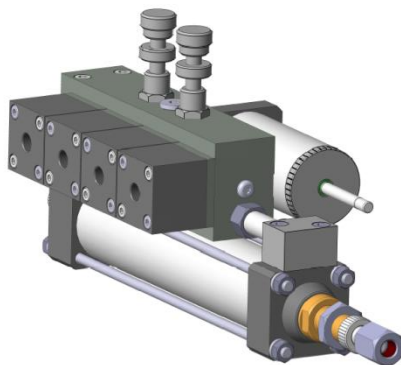

**SERIE 40**

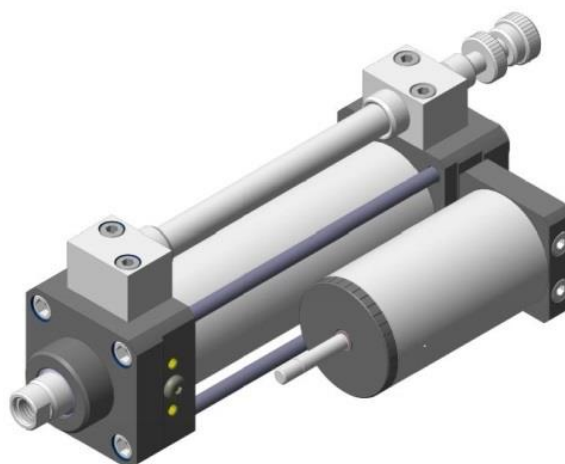

**CHIAVE DI CODIFICA – KEY TO CODES**

**EXEMPLES DE CODIFICATION – EJEMPLOS DE CODIFICACIÓN**

SERIE - SERIES SÉRIE - SERIE	SERBATOIO - TANK RÉSERVOIR - DEPÓSITO	REGOLAZIONE - REGULATION REGULATION - REGULACIÓN	CORSA - STROKE COURSE - CARRERA	TIPO VALVOLA - TYPE VALVE TYPE DE SOUPAPE - TIPO DE VÁLVULA			
<b>40</b>	<b>RL:</b> Serbatoio in linea In line tank Réservoir en ligne Dépósito en línea	<b>E:</b> Spinta (reg. rientro stelo) Thrust (piston rod return regulation) Poussée (régulation entrée de tige)	<b>050 mm.</b>	<b>NO:</b> Senza valvola - Without valve Aucun Soupape - Sin válvula <b>VA:</b> Valvola SKIP - SKIP valve Soupape SKIP - Válvula de SKIP <b>AS:</b> Valvola SKIP + STOP - SKIP + STOP valve Soupape SKIP + ARRÊT Válvula de SKIP + STOP <b>VS:</b> Valvola STOP - STOP valve - Soupape d'ARRÊT - Válvula de STOP <b>SP:</b> Speciale - Special - Spécial - Especial	<b>*C:</b> Valvola STOP normalmente chiusa STOP valve normally closed Soupape STOP normalement fermée Válvula STOP normalmente cerrada		
			<b>100 mm.</b>				
			<b>150 mm.</b>				
	<b>RP:</b> Serbatoio in parallelo In-parallel tank Réservoir en parallèle Depósito en paralelo	<b>U:</b> Trazione (reg. uscita stelo) Traction (piston rod out regulation) Traction (régulation sortie de tige) Tracción (regulación en salida vástago)	<b>200 mm.</b>				
			<b>250 mm.</b>				
			<b>300 mm.</b>				
						<b>350 mm.</b>	
						<b>400 mm.</b>	
						Corse speciali a richiesta Special stroke on demand Course spéciaux sur demand Carrera especial a pedido	

SERIE - SERIES SÉRIE - SERIE	SERBATOIO - TANK RÉSERVOIR - DEPÓSITO	REGOLAZIONE - REGULATION REGULATION - REGULACIÓN	CORSA - STROKE COURSE - CARRERA	TIPO VALVOLA - TYPE VALVE TYPE DE SOUPAPE - TIPO DE VÁLVULA		
<b>40</b>	<b>RP:</b> Serbatoio in parallelo In-parallel tank Réservoir en parallèle Depósito en paralelo	<b>D:</b> Doppia regolazione Dual regulation Double régulation Doble regulación	<b>050 mm.</b>	<b>NO:</b> Senza valvola - Without valve - Aucun Soupape - Sin válvula <b>SS:</b> Stop entrata/uscita - Stop in stroke/out stroke Soupape d'arrêt en entrée/sotie - Válvula de stop <b>SE:</b> Stop solo entrata - Stop in-stroke only Soupape d'arrêt en entrée - Válvula de stop entrata <b>SU:</b> Stop solo uscita - Stop out stroke only Soupape d'arrêt en sortie - Válvula de stop salida <b>AA:</b> Skip entrata/uscita - Skip in-stroke/out stroke Soupape de skip en entrée/sotie - Válvula de skip <b>AE:</b> Skip solo entrata - Skip in-stroke only Soupape de Skip en entrée - Válvula de skip entrata <b>AU:</b> Skip solo uscita - Skip out stroke only Soupape de Skip en sortie - Válvula de skip salida <b>SEAU:</b> Stop entrata/Skip uscita - Stop in-stroke / skip out-stroke Arrêt en entrée/Skip en sotie Válvula de stop entrata/skip salida <b>SUAE:</b> Stop uscita/Skip entrata - Stop out-stroke / skip in-stroke Arrêt en sortie/Skip en entrée Válvula de stop salida/skip entrata <b>ASAS:</b> Skip+Stop entrata/uscita - Skip+Stop in-stroke/out-stroke Skip+ Arrêt entrée/sortie - Válvula Skip+Stop entrata/salida	<b>*C:</b> Valvola STOP normalmente chiusa STOP valve normally closed Soupape STOP normalement fermée Válvula STOP normalmente cerrada	
			<b>100 mm.</b>			
			<b>150 mm.</b>			
			<b>200 mm.</b>			
			<b>250 mm.</b>			
			<b>300 mm.</b>			
			<b>350 mm.</b>			
			<b>400 mm.</b>			
						Corse speciali a richiesta Special stroke on demand Course spéciaux sur demande Carrera especial a pedido

\*A richiesta valvola di STOP normalmente chiusa. Aggiungere lettera "C"  
 STOP valve normally closed on demand. Add reference "C"  
 Soupape STOP normalement fermée sur demande. Ajouter référence "C"  
 Válvula STOP normalmente cerrada a pedido. Agregar la letra "C"

# Serie 40 - Serbatoio in linea - Regolazione in uscita stelo

## 40 serie - In line tank - Piston rod return regulation

### Séries 40 - Réservoir en ligne - Régulation sorti de tige

#### Serie 40 - Depósito en línea - Regulación en salida vástago



### 40.RLU ... NO

Senza valvola - Without valve - Aucun Soupape - Sin válvula

DATI TECNICI E DIMENSIONI - SPECIFICATIONS AND DIMENSIONS  
 DONNÉES TECHNIQUES ET DIMENSIONS - DATOS TÉCNICO Y TAMAÑOS

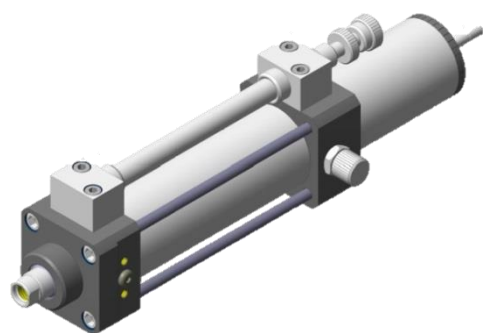

MODELLO - MODEL MODÈLE - MODELO	CORSA - STROKE COURSE - CARRERA	Dimensioni - Dimensions Dimensions - Tamaños			
		A	B	L	U
40.RLU.050.NO	50	136	80	245	32
40.RLU.100.NO	100	186	80	295	32
40.RLU.150.NO	150	236	100	365	47
40.RLU.200.NO	200	286	100	415	47
40.RLU.250.NO	250	336	125	490	67
40.RLU.300.NO	300	386	125	540	67
40.RLU.350.NO	350	436	145	610	86
40.RLU.400.NO	400	486	145	660	86

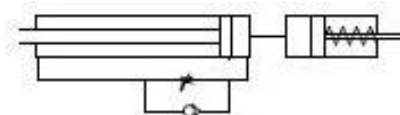
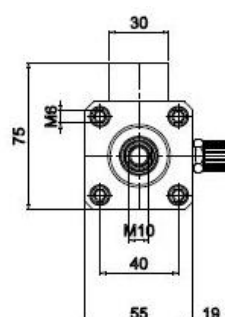
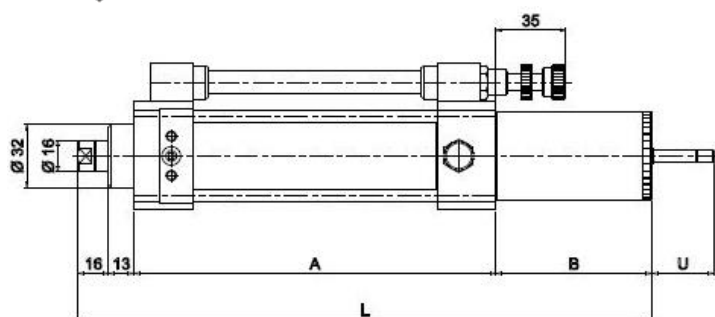

### 40.RLU ... AS - ASC

Valvola SKIP + STOP - SKIP + STOP valve - Soupape SKIP + ARRET - Válvula de SKIP + STOP

DATI TECNICI E DIMENSIONI - SPECIFICATIONS AND DIMENSIONS  
 DONNÉES TECHNIQUES ET DIMENSIONS - DATOS TÉCNICO Y TAMAÑOS

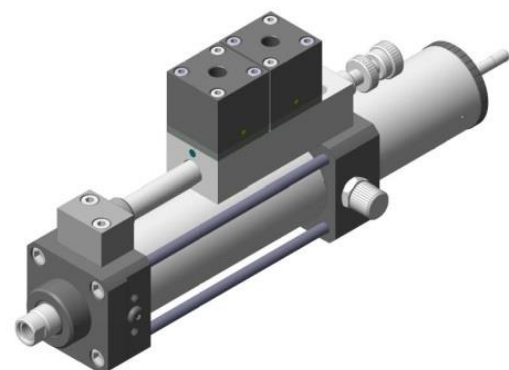

MODELLO - MODEL MODÈLE - MODELO	CORSA - STROKE COURSE - CARRERA	Dimensioni - Dimensions Dimensions - Tamaños			
		A	B	L	U
40.RLU.050.AS	50	136	80	245	32
40.RLU.100.AS	100	186	80	295	32
40.RLU.150.AS	150	236	100	365	47
40.RLU.200.AS	200	286	100	415	47
40.RLU.250.AS	250	336	125	490	67
40.RLU.300.AS	300	386	125	540	67
40.RLU.350.AS	350	436	145	610	86
40.RLU.400.AS	400	486	145	660	86

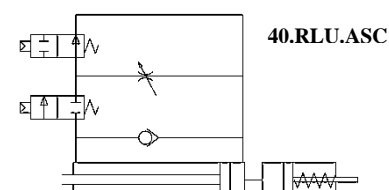
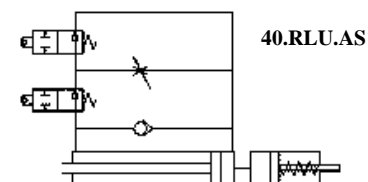
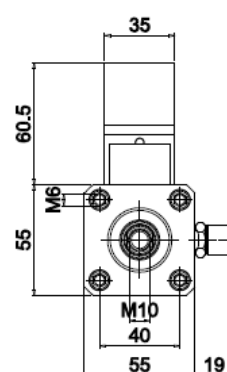
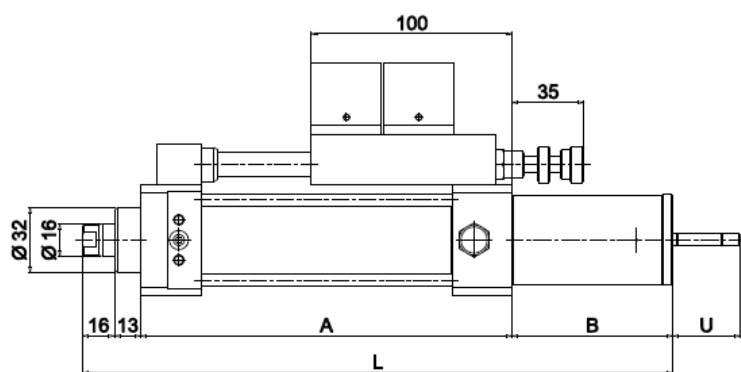



# Serie 40 - Serbatoio in linea - Regolazione in uscita stelo

## 40 serie - In line tank - Piston rod return regulation

### Séries 40 - Réservoir en ligne - Régulation sorti de tige

#### Serie 40 - Depósito en línea - Regulación en salida vástago



### 40.RLU ... VA Valvola SKIP - SKIP valve - Soupape SKIP - Válvula de SKIP

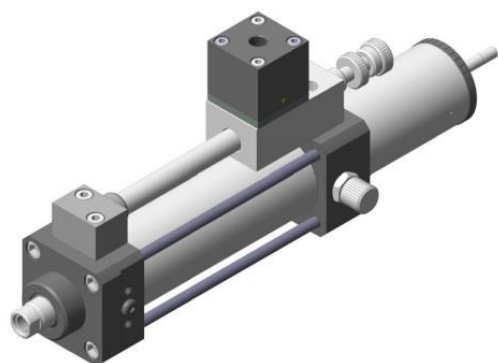

DATI TECNICI E DIMENSIONI - SPECIFICATIONS AND DIMENSIONS  
DONNÉES TECHNIQUES ET DIMENSIONS - DATOS TÉCNICO Y TAMAÑOS

MODELLO - MODEL MODÈLE - MODELO	CORSA - STROKE COURSE - CARRERA	Dimensioni - Dimensions Dimensions - Tamaños			
		A	B	L	U
40.RLU.050.VA	50	136	80	245	32
40.RLU.100.VA	100	186	80	295	32
40.RLU.150.VA	150	236	100	365	47
40.RLU.200.VA	200	286	100	415	47
40.RLU.250.VA	250	336	125	490	67
40.RLU.300.VA	300	386	125	540	67
40.RLU.350.VA	350	436	145	610	86
40.RLU.400.VA	400	486	145	660	86

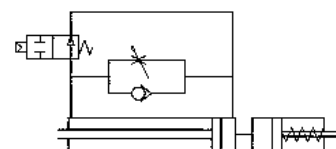
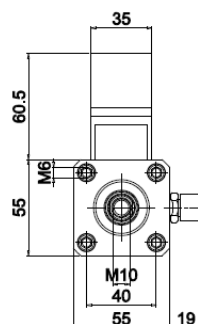
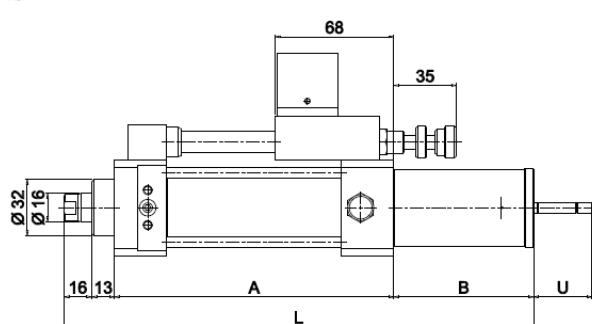

### 40.RLU ... VS - VSC Valvola STOP - STOP valve - Soupape d'ARRÊT - Válvula de STOP

DATI TECNICI E DIMENSIONI - SPECIFICATIONS AND DIMENSIONS  
DONNÉES TECHNIQUES ET DIMENSIONS - DATOS TÉCNICO Y TAMAÑOS

MODELLO - MODEL MODÈLE - MODELO	CORSA - STROKE COURSE - CARRERA	Dimensioni - Dimensions Dimensions - Tamaños			
		A	B	L	U
40.RLU.050.VS	50	136	80	245	32
40.RLU.100.VS	100	186	80	295	32
40.RLU.150.VS	150	236	100	365	47
40.RLU.200.VS	200	286	100	415	47
40.RLU.250.VS	250	336	125	490	67
40.RLU.300.VS	300	386	125	540	67
40.RLU.350.VS	350	436	145	610	86
40.RLU.400.VS	400	486	145	660	86

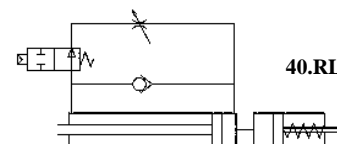
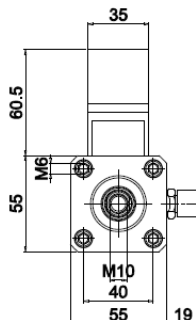
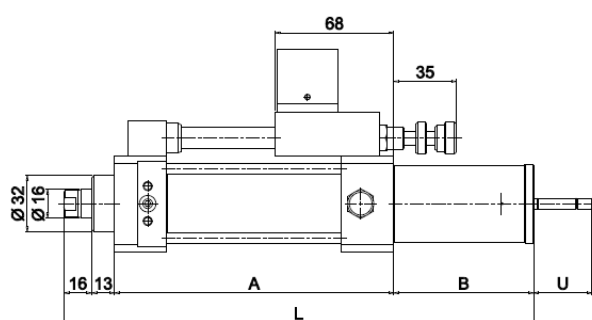
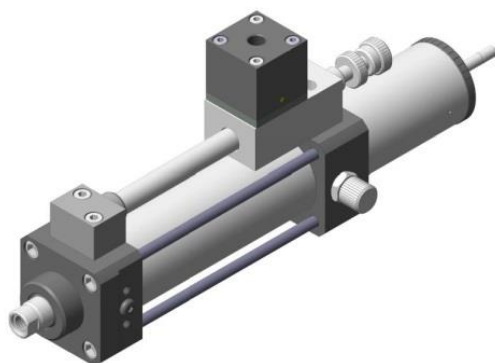

40.RLU.VS

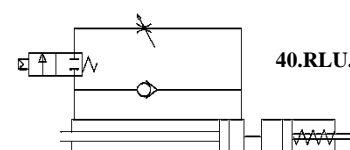

40.RLU.VSC

# Serie 40 - Serbatoio inparallelo - Regolazione in uscita stelo

## 40 serie - In-parallel tank- Piston rod return regulation

### Séries 40 - Réservoir en parallèle - Régulation sorti de tige

### Serie 40 - Depósito en paralelo - Regulación en salida vástago



#### 40.RPU ... NO

Senza valvola - Without valve - Aucun Soupape - Sin válvula

DATI TECNICI E DIMENSIONI - SPECIFICATIONS AND DIMENSIONS  
DONNÉES TECHNIQUES ET DIMENSIONS - DATOS TÉCNICO Y TAMAÑOS

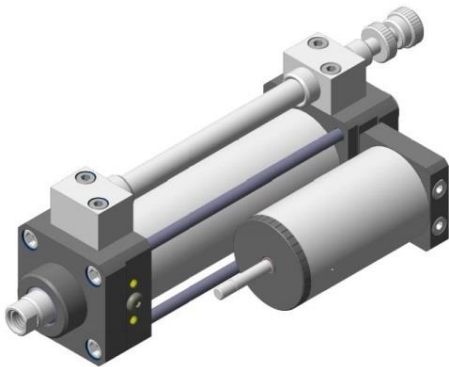

MODELLO - MODEL MODÈLE - MODELO	CORSA - STROKE COURSE - CARRERA	Dimensioni - Dimensions Dimensions - Tamaños			
		A	B	L	U
40.RPU.050.NO	50	136	105	165	32
40.RPU.100.NO	100	186	105	215	32
40.RPU.150.NO	150	236	125	265	47
40.RPU.200.NO	200	286	125	315	47
40.RPU.250.NO	250	336	150	365	67
40.RPU.300.NO	300	386	150	415	67
40.RPU.350.NO	350	436	170	465	86
40.RPU.400.NO	400	486	170	515	86

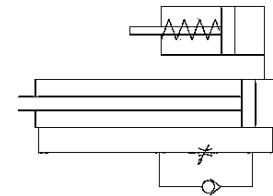
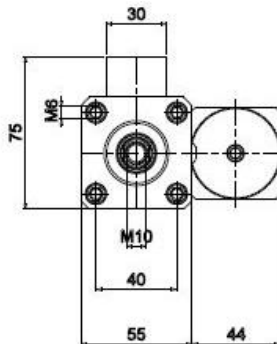
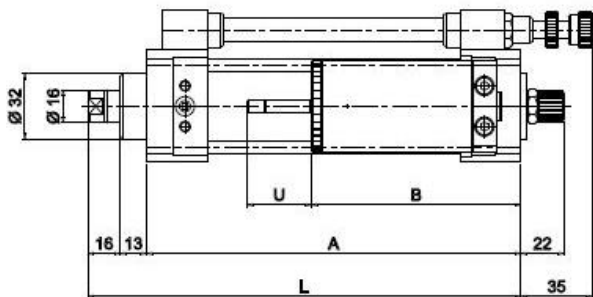

#### 40.RPU ... AS - ASC

Valvola SKIP + STOP - SKIP + STOP valve - Soupape SKIP + ARRET - Válvula de SKIP + STOP

DATI TECNICI E DIMENSIONI - SPECIFICATIONS AND DIMENSIONS  
DONNÉES TECHNIQUES ET DIMENSIONS - DATOS TÉCNICO Y TAMAÑOS

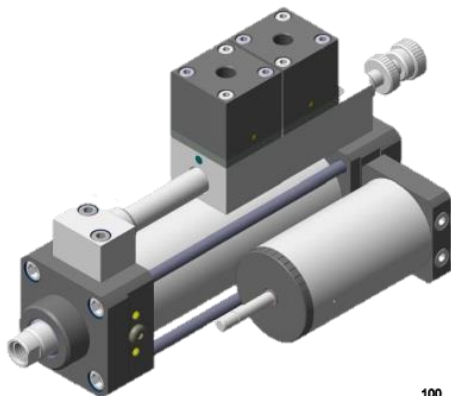

MODELLO - MODEL MODÈLE - MODELO	CORSA - STROKE COURSE - CARRERA	Dimensioni - Dimensions Dimensions - Tamaños			
		A	B	L	U
40.RPU.050.AS	50	136	105	165	32
40.RPU.100.AS	100	186	105	215	32
40.RPU.150.AS	150	236	125	265	47
40.RPU.200.AS	200	286	125	315	47
40.RPU.250.AS	250	336	150	365	67
40.RPU.300.AS	300	386	150	415	67
40.RPU.350.AS	350	436	170	465	86
40.RPU.400.AS	400	486	170	515	86

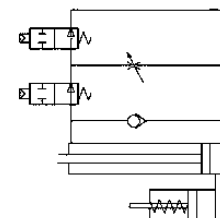
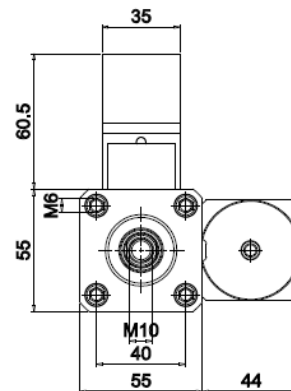
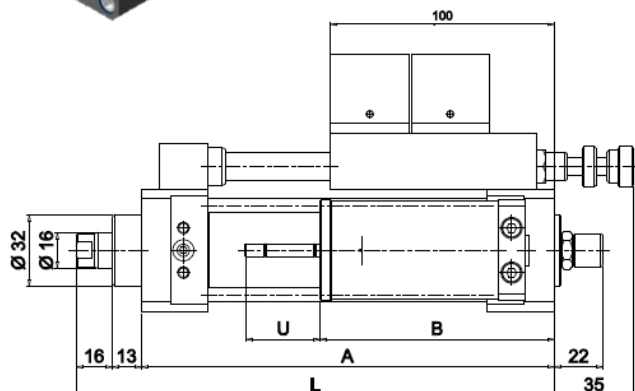

40.RPU.AS

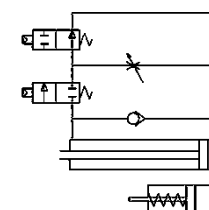

40.RPU.ASC

# Serie 40 - Serbatoio inparallelo - Regolazione in uscita stelo

## 40 serie - In-parallel tank- Piston rod return regulation

### Séries 40 - Réservoir en parallèle - Régulation sorti de tige

### Serie 40 - Depósito en paralelo - Regulación en salida vástago



#### 40.RPU ... VA

Valvola SKIP - SKIP valve - Soupape SKIP - Válvula de SKIP

DATI TECNICI E DIMENSIONI - SPECIFICATIONS AND DIMENSIONS  
DONNÉES TECHNIQUES ET DIMENSIONS - DATOS TÉCNICO Y TAMAÑOS

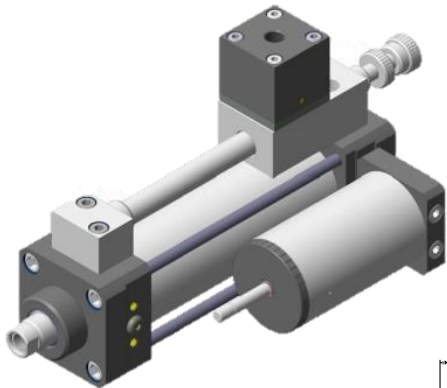

MODELLO - MODEL MODÈLE - MODELO	CORSA - STROKE COURSE - CARRERA	Dimensioni - Dimensions Dimensions - Tamaños			
		A	B	L	U
40.RPU.050.VA	50	136	105	165	32
40.RPU.100.VA	100	186	105	215	32
40.RPU.150.VA	150	236	125	265	47
40.RPU.200.VA	200	286	125	315	47
40.RPU.250.VA	250	336	150	365	67
40.RPU.300.VA	300	386	150	415	67
40.RPU.350.VA	350	436	170	465	86
40.RPU.400.VA	400	486	170	515	86

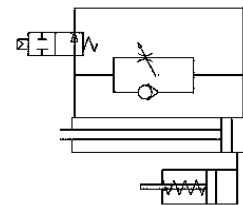
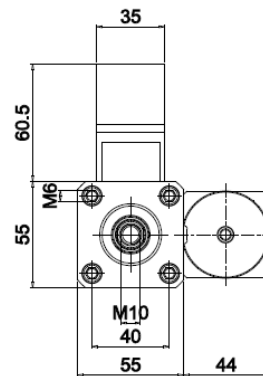
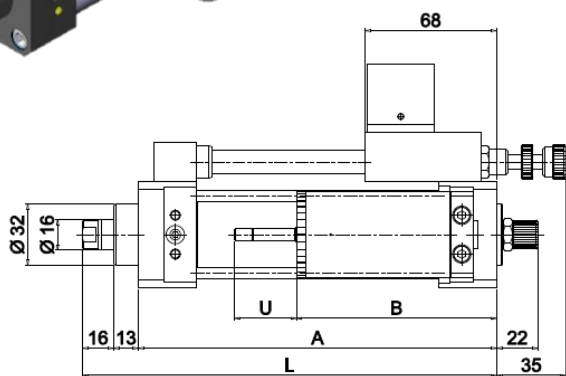

#### 40.RPU ... VS - VSC

Valvola STOP - STOP valve - Soupape d'ARRÊT - Válvula de STOP

DATI TECNICI E DIMENSIONI - SPECIFICATIONS AND DIMENSIONS  
DONNÉES TECHNIQUES ET DIMENSIONS - DATOS TÉCNICO Y TAMAÑOS

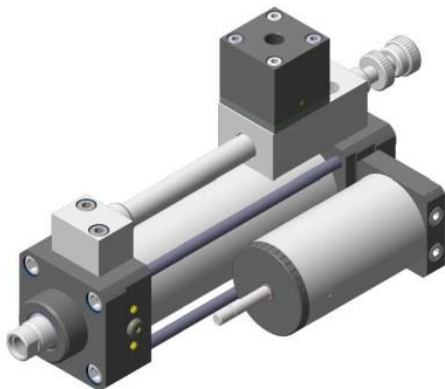

MODELLO - MODEL MODÈLE - MODELO	CORSA - STROKE COURSE - CARRERA	Dimensioni - Dimensions Dimensions - Tamaños			
		A	B	L	U
40.RPU.050.VS	50	136	105	165	32
40.RPU.100.VS	100	186	105	215	32
40.RPU.150.VS	150	236	125	265	47
40.RPU.200.VS	200	286	125	315	47
40.RPU.250.VS	250	336	150	365	67
40.RPU.300.VS	300	386	150	415	67
40.RPU.350.VS	350	436	170	465	86
40.RPU.400.VS	400	486	170	515	86

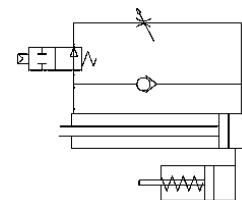
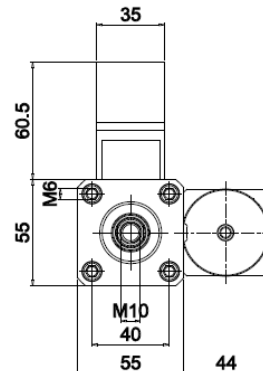
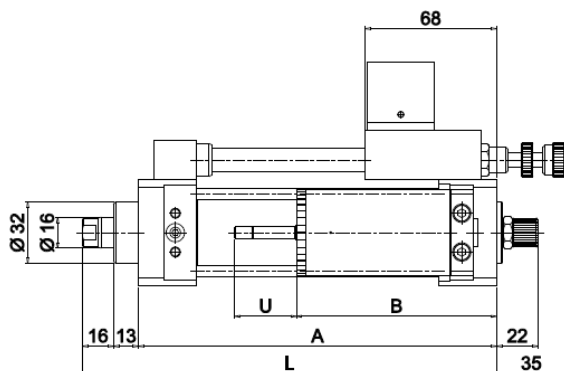

40.RPU.VS

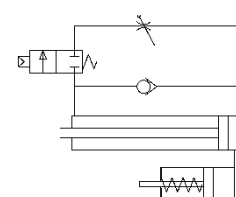

40.RPU.VSC

# Serie 40 - Serbatoio in parallelo - Regolazione in entrata stelo

# 40 serie - In-parallel tank- Piston rod return regulation

# Séries 40 - Réservoir en parallèle - Régulation entrée de tige

# Serie 40 - Depósito en paralelo - Regulación en entrada vástago



## 40.RPE ... NO

Senza valvola - Without valve - Aucun Soupape - Sin válvula

DATI TECNICI E DIMENSIONI - SPECIFICATIONS AND DIMENSIONS  
DONNÉES TECHNIQUES ET DIMENSIONS - DATOS TÉCNICO Y TAMAÑOS

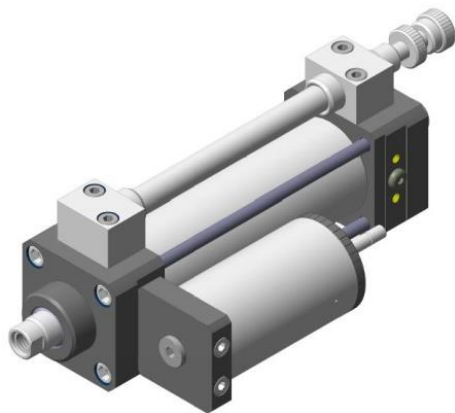

MODELLO - MODEL MODÈLE - MODELO	CORSA - STROKE COURSE - CARRERA	Dimensioni - Dimensions Dimensions - Tamaños			
		A	B	L	U
40.RPE.050.NO	50	136	105	165	32
40.RPE.100.NO	100	186	105	215	32
40.RPE.150.NO	150	236	125	265	47
40.RPE.200.NO	200	286	125	315	47
40.RPE.250.NO	250	336	150	365	67
40.RPE.300.NO	300	386	150	415	67
40.RPE.350.NO	350	436	170	465	86
40.RPE.400.NO	400	486	170	515	86

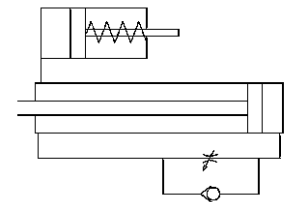
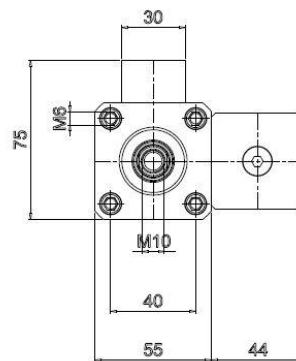
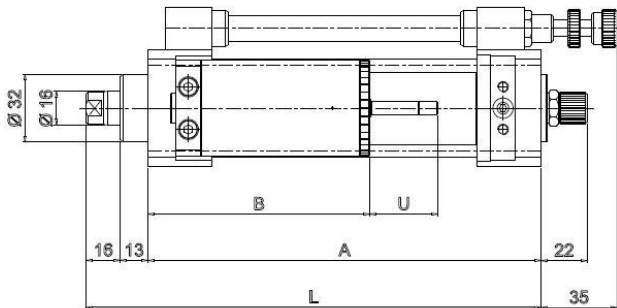

## 40.RPE ... AS - ASC

Valvola SKIP + STOP - SKIP + STOP valve - Soupape SKIP + ARRET - Válvula de SKIP + STOP

DATI TECNICI E DIMENSIONI - SPECIFICATIONS AND DIMENSIONS  
DONNÉES TECHNIQUES ET DIMENSIONS - DATOS TÉCNICO Y TAMAÑOS

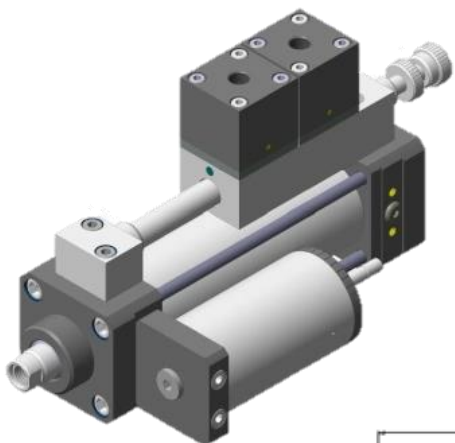

MODELLO - MODEL MODÈLE - MODELO	CORSA - STROKE COURSE - CARRERA	Dimensioni - Dimensions Dimensions - Tamaños			
		A	B	L	U
40.RPE.050.AS	50	136	105	165	32
40.RPE.100.AS	100	186	105	215	32
40.RPE.150.AS	150	236	125	265	47
40.RPE.200.AS	200	286	125	315	47
40.RPE.250.AS	250	336	150	365	67
40.RPE.300.AS	300	386	150	415	67
40.RPE.350.AS	350	436	170	465	86
40.RPE.400.AS	400	486	170	515	86

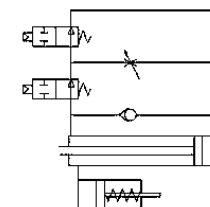
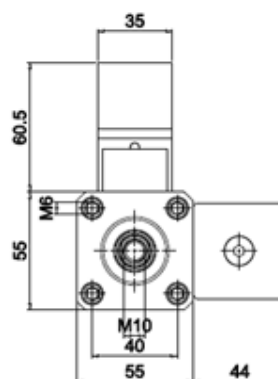
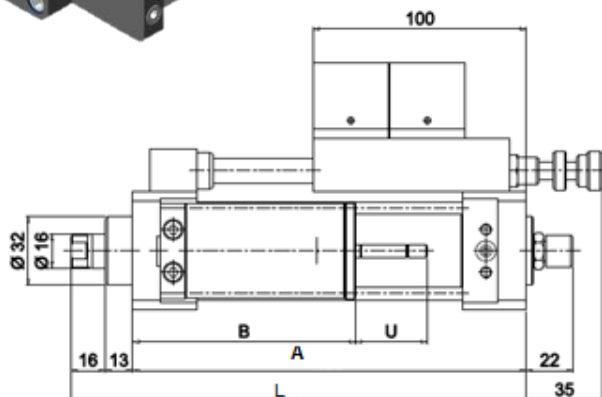

40.RPE.AS

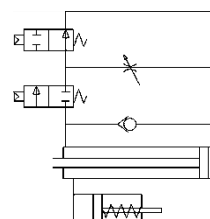

40.RPE.ASC

# Serie 40 - Serbatoio in parallelo - Regolazione in entrata stelo

# 40 serie - In-parallel tank- Piston rod return regulation

# Séries 40 - Réservoir en parallèle - Régulation entrée de tige

# Serie 40 - Depósito en paralelo - Regulación en entrada vástago



**ENERFLUID**

## 40.RPE ... VA

Valvola SKIP - SKIP valve - Soupape SKIP - Válvula de SKIP

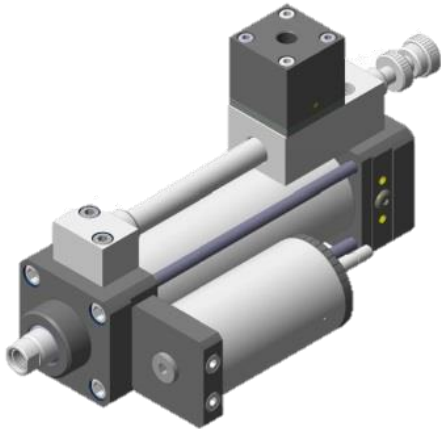

DATI TECNICI E DIMENSIONI - SPECIFICATIONS AND DIMENSIONS  
DONNÉES TECHNIQUES ET DIMENSIONS - DATOS TÉCNICO Y TAMAÑOS

MODELLO - MODEL MODÈLE - MODELO	CORSA - STROKE COURSE - CARRERA	Dimensioni - Dimensions Dimensions - Tamaños			
		A	B	L	U
40.RPE.050.VA	50	136	105	165	32
40.RPE.100.VA	100	186	105	215	32
40.RPE.150.VA	150	236	125	265	47
40.RPE.200.VA	200	286	125	315	47
40.RPE.250.VA	250	336	150	365	67
40.RPE.300.VA	300	386	150	415	67
40.RPE.350.VA	350	436	170	465	86
40.RPE.400.VA	400	486	170	515	86

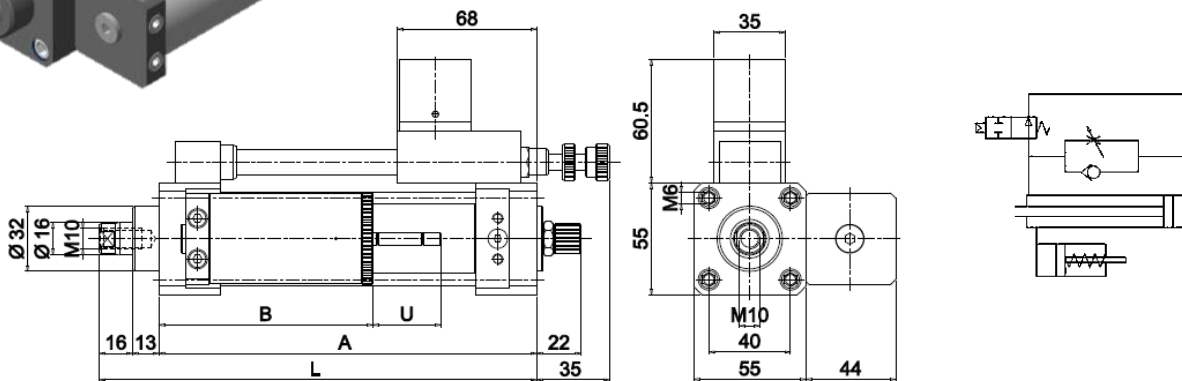

## 40.RPE ... VS - VSC

Valvola STOP - STOP valve - Soupape d'ARRÊT - Válvula de STOP

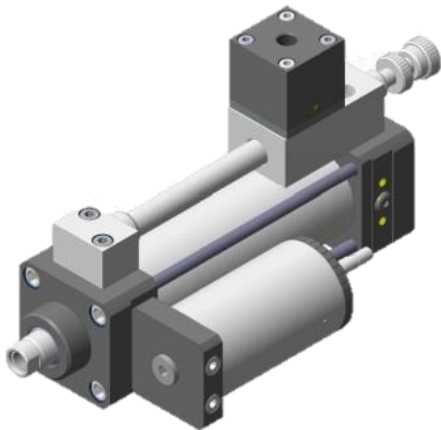

DATI TECNICI E DIMENSIONI - SPECIFICATIONS AND DIMENSIONS  
DONNÉES TECHNIQUES ET DIMENSIONS - DATOS TÉCNICO Y TAMAÑOS

MODELLO - MODEL MODÈLE - MODELO	CORSA - STROKE COURSE - CARRERA	Dimensioni - Dimensions Dimensions - Tamaños			
		A	B	L	U
40.RPE.050.VS	50	136	105	165	32
40.RPE.100.VS	100	186	105	215	32
40.RPE.150.VS	150	236	125	265	47
40.RPE.200.VS	200	286	125	315	47
40.RPE.250.VS	250	336	150	365	67
40.RPE.300.VS	300	386	150	415	67
40.RPE.350.VS	350	436	170	465	86
40.RPE.400.VS	400	486	170	515	86

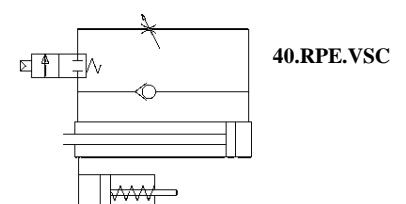
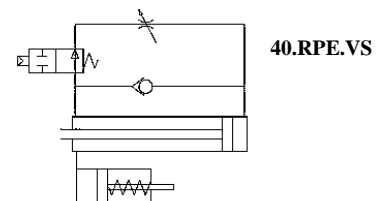
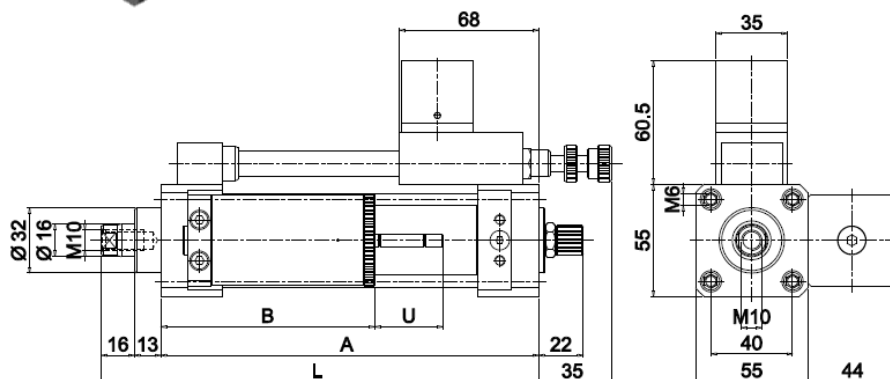

Serie 40 - Serbatoio in parallelo - Doppia regolazione  
 40 serie - In-parallel tank- Dual regulation

Séries 40 - Réservoir en parallèle - Double régulation

Serie 40 - Depósito en paralelo - Doble regulación



**40.RPD ... NO**

Senza valvola - Without valve - Aucun Soupape - Sin válvula

DATI TECNICI E DIMENSIONI - SPECIFICATIONS AND DIMENSIONS  
 DONNÉES TECHNIQUES ET DIMENSIONS - DATOS TÉCNICO Y TAMAÑOS

MODELLO - MODEL MODÈLE - MODELO	CORSA - STROKE COURSE - CARRERA	Dimensioni - Dimensions Dimensions - Tamaños			
		A	B	L	U
40.RPD.050.NO	50	136	138	165	32
40.RPD.100.NO	100	186	138	215	32
40.RPD.150.NO	150	236	158	265	47
40.RPD.200.NO	200	286	158	315	47
40.RPD.250.NO	250	336	183	365	67
40.RPD.300.NO	300	386	183	415	67
40.RPD.350.NO	350	436	203	465	86
40.RPD.400.NO	400	486	203	515	86

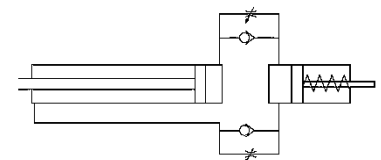
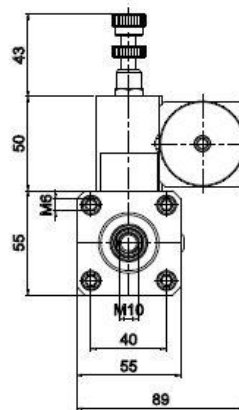
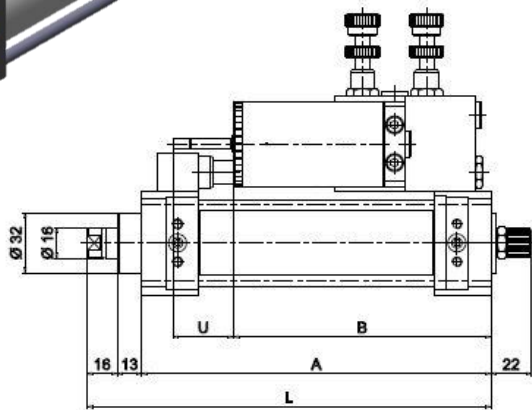
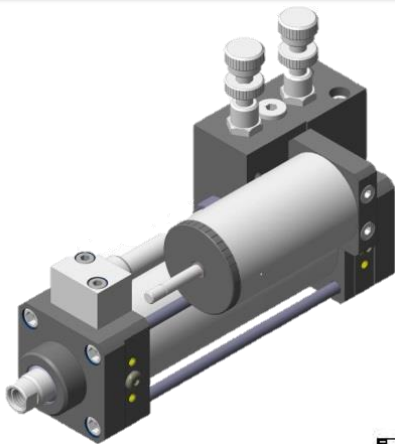

**40.RPD ... AA**

Skip entrata/uscita - Skip in-stroke/out stroke - Soupape de skip en entrée/sotie - Válvula de skip

DATI TECNICI E DIMENSIONI - SPECIFICATIONS AND DIMENSIONS  
 DONNÉES TECHNIQUES ET DIMENSIONS - DATOS TÉCNICO Y TAMAÑOS

MODELLO - MODEL MODÈLE - MODELO	CORSA - STROKE COURSE - CARRERA	Dimensioni - Dimensions Dimensions - Tamaños			
		A	B	L	U
40.RPD.050.AA	50	136	138	165	32
40.RPD.100.AA	100	186	138	215	32
40.RPD.150.AA	150	236	158	265	47
40.RPD.200.AA	200	286	158	315	47
40.RPD.250.AA	250	336	183	365	67
40.RPD.300.AA	300	386	183	415	67
40.RPD.350.AA	350	436	203	465	86
40.RPD.400.AA	400	486	203	515	86

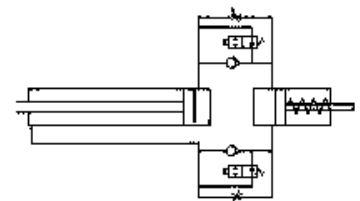
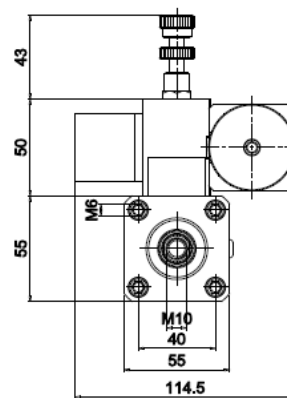
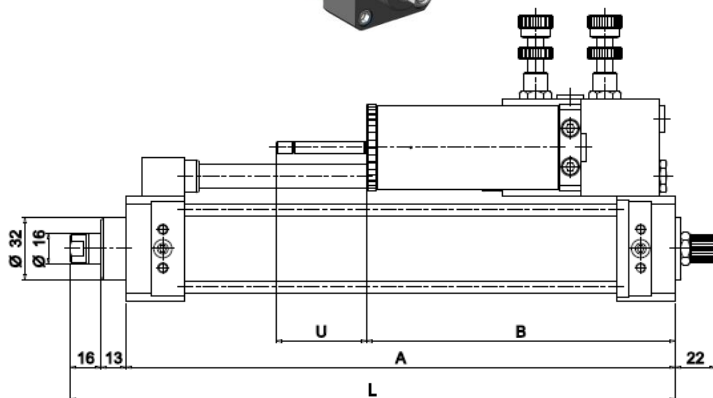
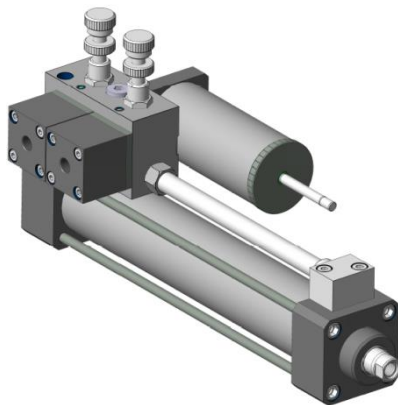

Serie 40 - Serbatoio in parallelo - Doppia regolazione  
 40 serie - In-parallel tank- Dual regulation

Séries 40 - Réservoir en parallèle - Double régulation

Serie 40 - Depósito en paralelo - Doble regulación



**40.RPD ... AE** Skip solo entrata - Skip in-stroke only

DATI TECNICI E DIMENSIONI - SPECIFICATIONS AND DIMENSIONS  
 DONNÉES TECHNIQUES ET DIMENSIONS - DATOS TÉCNICO Y TAMAÑOS

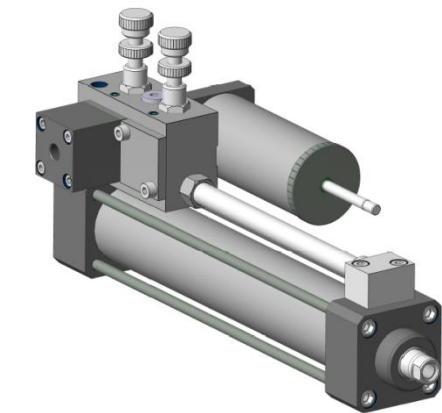

MODELLO - MODEL MODÈLE - MODELO	CORSA - STROKE COURSE - CARRERA	Dimensioni - Dimensions Dimensions - Tamaños			
		A	B	L	U
40.RPD.050.AE	50	136	138	165	32
40.RPD.100.AE	100	186	138	215	
40.RPD.150.AE	150	236	158	265	47
40.RPD.200.AE	200	286		315	
40.RPD.250.AE	250	336	183	365	67
40.RPD.300.AE	300	386		415	
40.RPD.350.AE	350	436	203	465	86
40.RPD.400.AE	400	486		515	

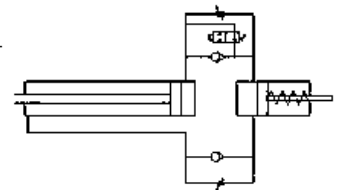
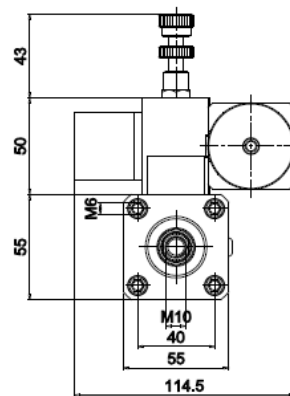
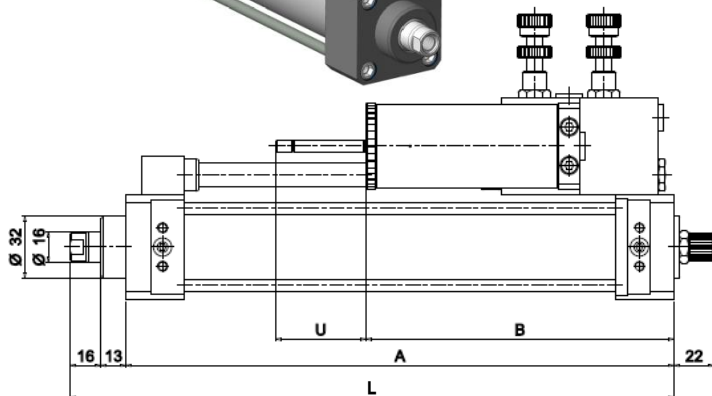

**40.RPD ... AU** Skip solo uscita - Skip out stroke only - Soupape de Skip en sortie - Válvula de skip salida

DATI TECNICI E DIMENSIONI - SPECIFICATIONS AND DIMENSIONS  
 DONNÉES TECHNIQUES ET DIMENSIONS - DATOS TÉCNICO Y TAMAÑOS

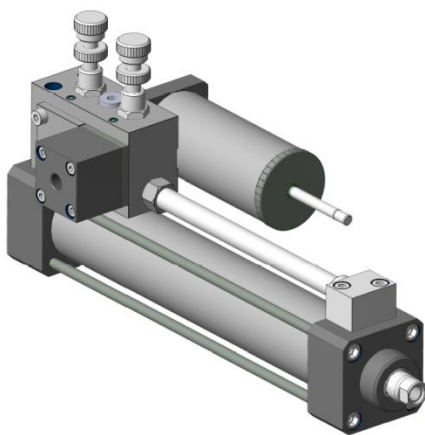

MODELLO - MODEL MODÈLE - MODELO	CORSA - STROKE COURSE - CARRERA	Dimensioni - Dimensions Dimensions - Tamaños			
		A	B	L	U
40.RPD.050.AU	50	136	138	165	32
40.RPD.100.AU	100	186	138	215	
40.RPD.150.AU	150	236	158	265	47
40.RPD.200.AU	200	286		315	
40.RPD.250.AU	250	336	183	365	67
40.RPD.300.AU	300	386		415	
40.RPD.350.AU	350	436	203	465	86
40.RPD.400.AU	400	486		515	

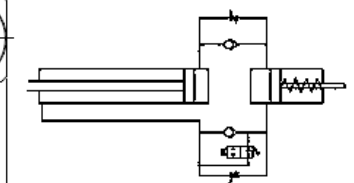
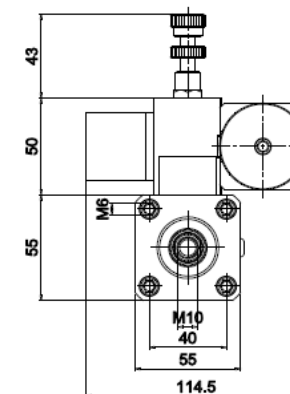
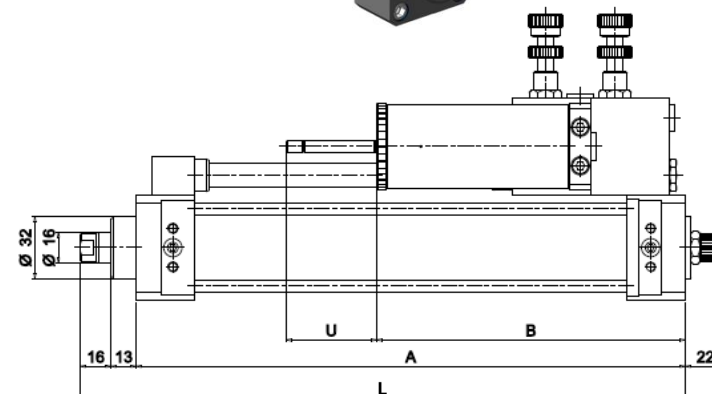

Serie 40 - Serbatoio in parallelo - Doppia regolazione  
 40 serie - In-parallel tank- Dual regulation

Séries 40 - Réservoir en parallèle - Double régulation

Serie 40 - Depósito en paralelo - Doble regulación



**40.RPD ... SS - SSC** Stop entrata/uscita - Stop in stroke/out stroke - Soupape d'arrêt en entrée/sotie - Válvula de stop

DATI TECNICI E DIMENSIONI - SPECIFICATIONS AND DIMENSIONS  
 DONNÉES TECHNIQUES ET DIMENSIONS - DATOS TÉCNICO Y TAMAÑOS

MODELLO - MODEL MODÈLE - MODELO	CORSA - STROKE COURSE - CARRERA	Dimensioni - Dimensions Dimensions - Tamaños			
		A	B	L	U
40.RPD.050.SS	50	136	138	165	32
40.RPD.100.SS	100	186	138	215	32
40.RPD.150.SS	150	236	158	265	47
40.RPD.200.SS	200	286	158	315	47
40.RPD.250.SS	250	336	183	365	67
40.RPD.300.SS	300	386	183	415	67
40.RPD.350.SS	350	436	203	465	86
40.RPD.400.SS	400	486	203	515	86

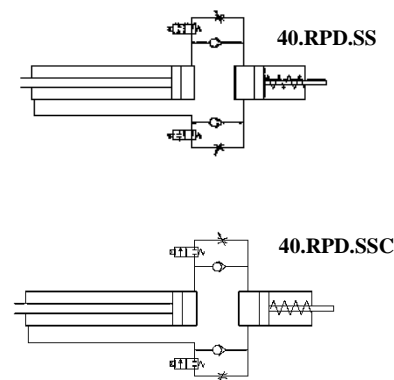
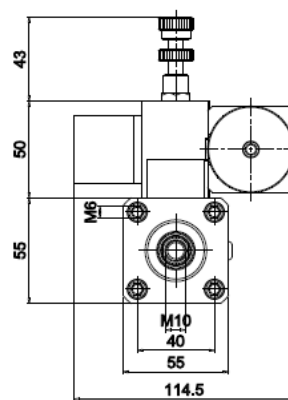
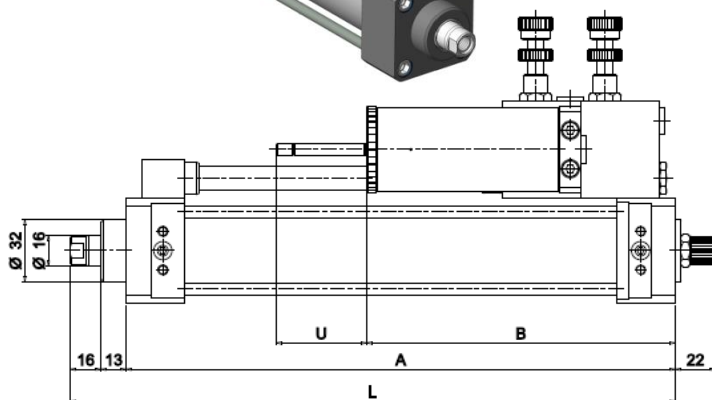
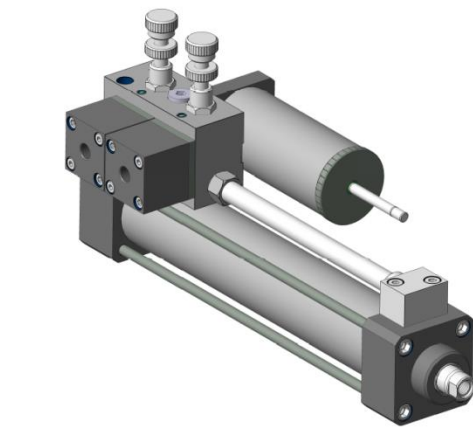

**40.RPD ... SE - SEC** Stop solo entrata - Stop in-stroke only - Soupape d'arrêt en entrée - Válvula de stop entrada

DATI TECNICI E DIMENSIONI - SPECIFICATIONS AND DIMENSIONS  
 DONNÉES TECHNIQUES ET DIMENSIONS - DATOS TÉCNICO Y TAMAÑOS

MODELLO - MODEL MODÈLE - MODELO	CORSA - STROKE COURSE - CARRERA	Dimensioni - Dimensions Dimensions - Tamaños			
		A	B	L	U
40.RPD.050.SE	50	136	138	165	32
40.RPD.100.SE	100	186	138	215	32
40.RPD.150.SE	150	236	158	265	47
40.RPD.200.SE	200	286	158	315	47
40.RPD.250.SE	250	336	183	365	67
40.RPD.300.SE	300	386	183	415	67
40.RPD.350.SE	350	436	203	465	86
40.RPD.400.SE	400	486	203	515	86

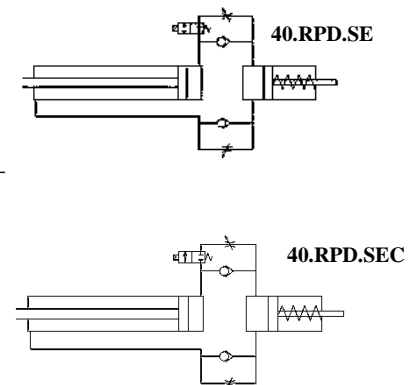
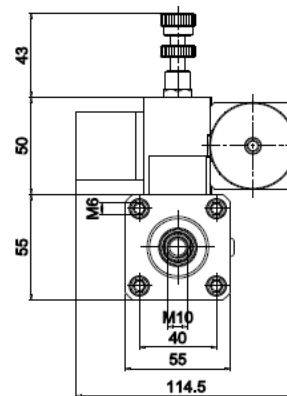
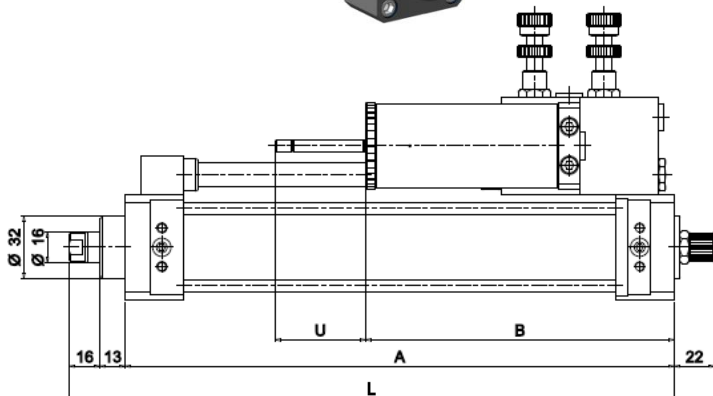
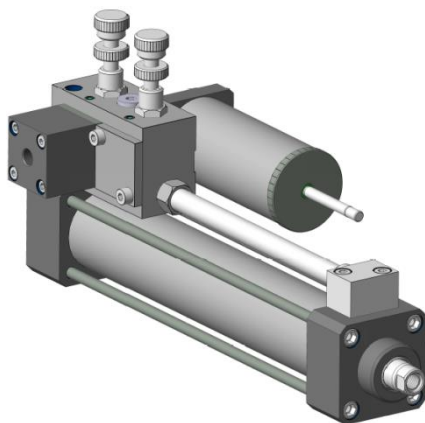



Serie 40 - Serbatoio in parallelo - Doppia regolazione  
 40 serie - In-parallel tank- Dual regulation

Séries 40 - Réservoir en parallèle - Double régulation

Serie 40 - Depósito en paralelo - Doble regulación



**40.RPD ... SU - SUC** Stop solo uscita – Stop out stroke only - Soupape d'arrêt en sortie - Válvula de stop salida

DATI TECNICI E DIMENSIONI – SPECIFICATIONS AND DIMENSIONS  
 DONNÉES TECHNIQUES ET DIMENSIONS – DATOS TÉCNICO Y TAMAÑOS

MODELLO - MODEL MODÈLE - MODELO	CORSA - STROKE COURSE - CARRERA	Dimensioni – Dimensions Dimensions - Tamaños			
		A	B	L	U
40.RPD.050.SU	50	136		165	
40.RPD.100.SU	100	186	138	215	32
40.RPD.150.SU	150	236		265	
40.RPD.200.SU	200	286	158	315	47
40.RPD.250.SU	250	336		365	
40.RPD.300.SU	300	386	183	415	67
40.RPD.350.SU	350	436		465	
40.RPD.400.SU	400	486	203	515	86

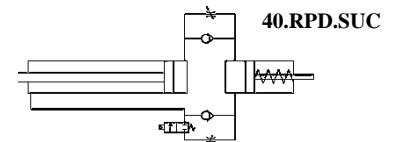
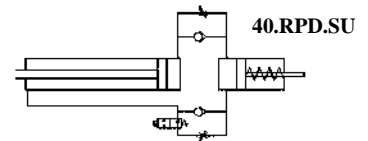
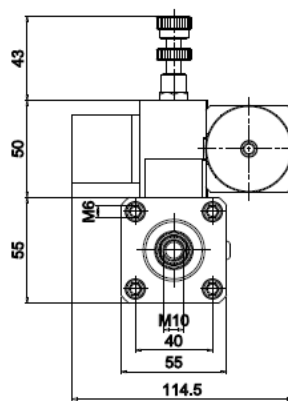
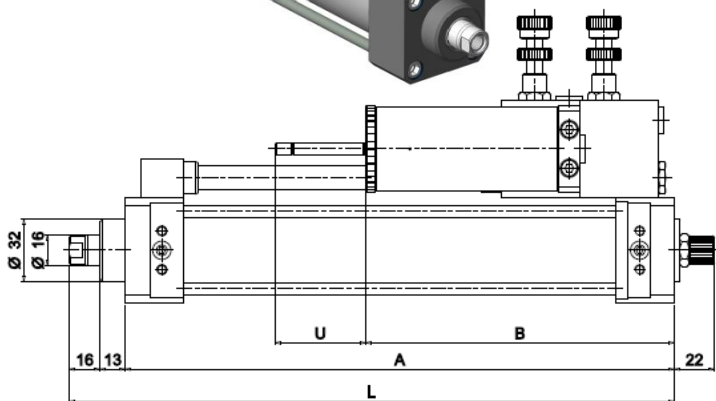
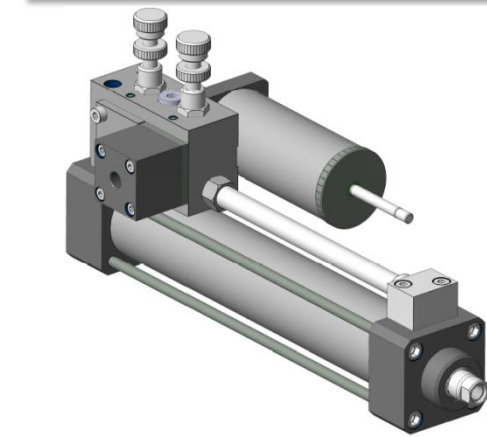

**40.RPD ... SEAU - SEauc**

Stop entrata/Skip uscita – Stop in-stroke / skip out-stroke -  
 Arrêt en entrée/Skip en sortie - Válvula de stop entrada/skip salida

DATI TECNICI E DIMENSIONI – SPECIFICATIONS AND DIMENSIONS  
 DONNÉES TECHNIQUES ET DIMENSIONS – DATOS TÉCNICO Y TAMAÑOS

MODELLO - MODEL MODÈLE - MODELO	CORSA - STROKE COURSE - CARRERA	Dimensioni – Dimensions Dimensions - Tamaños			
		A	B	L	U
40.RPD.050.SEAU	50	136		165	
40.RPD.100.SEAU	100	186	138	215	32
40.RPD.150.SEAU	150	236		265	
40.RPD.200.SEAU	200	286	158	315	47
40.RPD.250.SEAU	250	336		365	
40.RPD.300.SEAU	300	386	183	415	67
40.RPD.350.SEAU	350	436		465	
40.RPD.400.SEAU	400	486	203	515	86

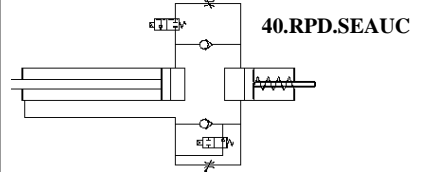
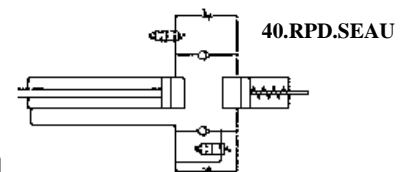
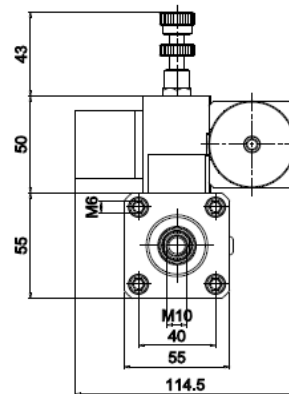
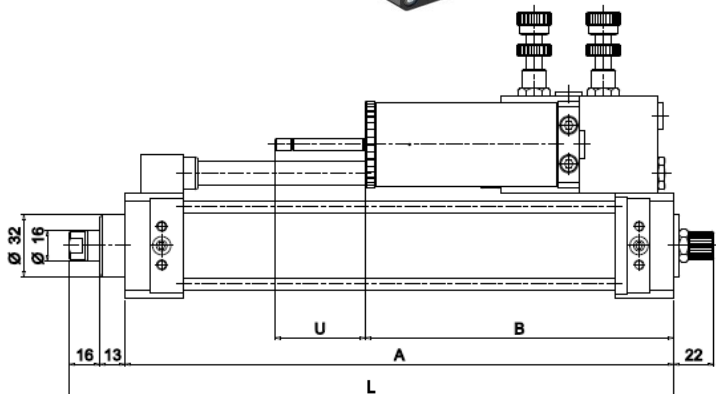
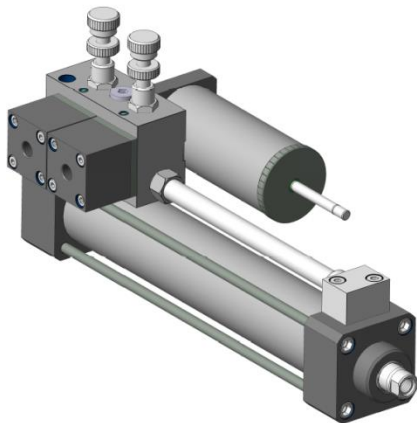

Serie 40 - Serbatoio in parallelo - Doppia regolazione  
 40 serie - In-parallel tank- Dual regulation

Séries 40 - Réservoir en parallèle - Double régulation

Serie 40 - Depósito en paralelo - Doble regulación



**40.RPD ... SVAE - SVAEC**

Stop uscita/Skip entrata - Stop out-stroke / skip in-stroke  
 Arrêt en sortie/Skip en entrée - Válvula de stop salida/skip entrada

DATI TECNICI E DIMENSIONI - SPECIFICATIONS AND DIMENSIONS  
 DONNÉES TECHNIQUES ET DIMENSIONS - DATOS TÉCNICO Y TAMAÑOS

MODELLO - MODEL MODÈLE - MODELO	CORSA - STROKE COURSE - CARRERA	Dimensioni - Dimensions Dimensions - Tamaños			
		A	B	L	U
40.RPD.050.SVAE	50	136	138	165	32
40.RPD.100.SVAE	100	186		215	
40.RPD.150.SVAE	150	236	158	265	47
40.RPD.200.SVAE	200	286		315	
40.RPD.250.SVAE	250	336	183	365	67
40.RPD.300.SVAE	300	386		415	
40.RPD.350.SVAE	350	436	203	465	86
40.RPD.400.SVAE	400	486		515	

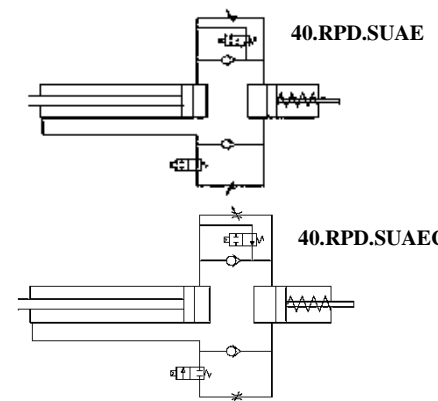
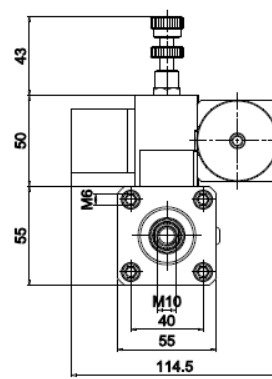
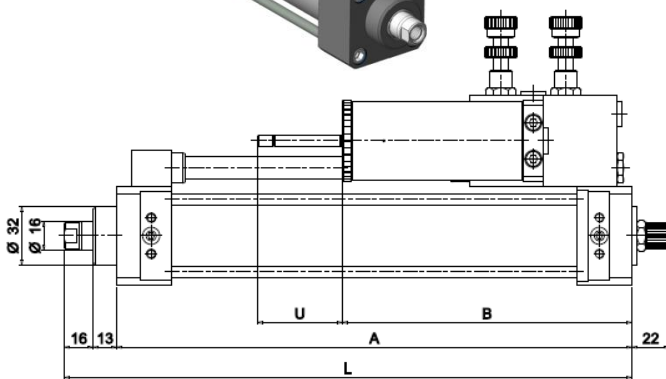
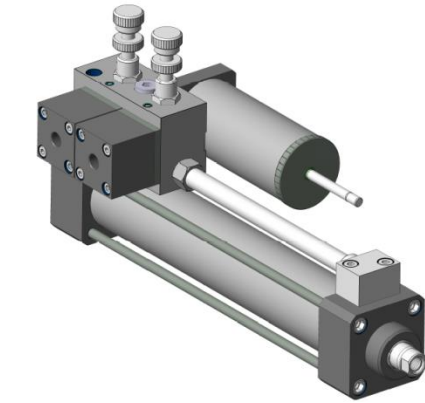

**40.RPD ... ASAS - ASASC**

Skip+Stop entrata/uscita - Skip+Stop in-stroke/out-stroke  
 Skip+ Arrêt entrée/sortie - Válvula Skip+Stop entrada/salida

DATI TECNICI E DIMENSIONI - SPECIFICATIONS AND DIMENSIONS  
 DONNÉES TECHNIQUES ET DIMENSIONS - DATOS TÉCNICO Y TAMAÑOS

MODELLO - MODEL MODÈLE - MODELO	CORSA - STROKE COURSE - CARRERA	Dimensioni - Dimensions Dimensions - Tamaños			
		A	B	L	U
40.RPD.150.ASAS	150	236	158	265	47
40.RPD.200.ASAS	200	286		315	
40.RPD.250.ASAS	250	336	183	365	67
40.RPD.300.ASAS	300	386		415	
40.RPD.350.ASAS	350	436	203	465	86
40.RPD.400.ASAS	400	486		515	

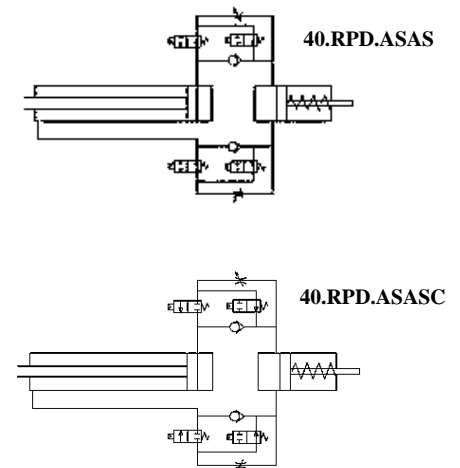
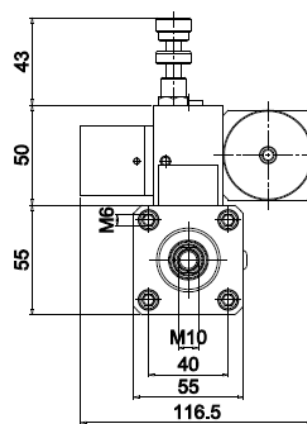
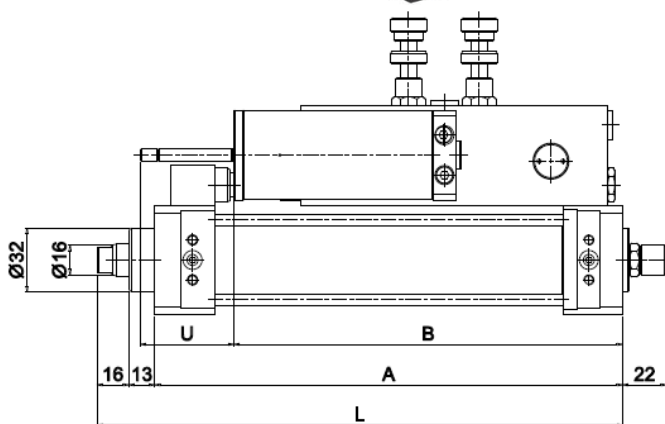
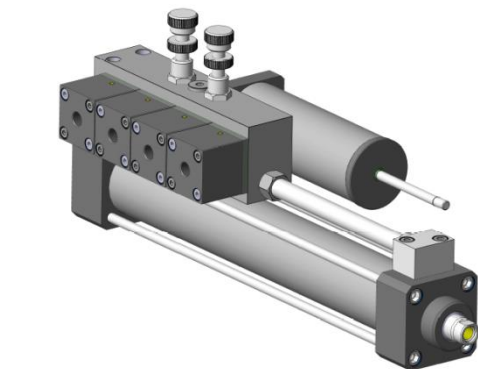

**Valvole di controllo per regolatori idraulici serie 35-40**  
**Control valves for hydraulic speed regulators Series 35-40**  
**Soupapes de contrôle pour régulateurs de vitesse Séries 35-40**  
**Válvulas de control para reguladores de velocidad Serie 35-40**



**APPLICAZIONI**



Queste valvole sono montate a richiesta sui **REGOLATORI IDRAULICI DI VELOCITA**.

Sono normalmente aperte e comandate

pneumaticamente ad una pressione massima di 8 bar e possono essere usate separatamente dai regolatori per intercettare fluidi in trasferimento.

**APPLICATIONS**



These valves can be mounted on **HYDRAULIC SPEED REGULATORS**.

They are normally open and pneumatically controlled at 8 bar max. pressure.

They can be used separately from speed regulators to intercept fluids in the system.

**APPLICATIONS**



Ces soupapes sont montées sur le **RÉGULATEURS HYDRAULIQUES DE VITESSE** sur demande. Elles sont normalement

ouvertes et commandées pneumatiquement à une pression maximale de 8 bars; elles peuvent être utilisées séparément pour contrôler les fluides en transfert.

**APLICACIONES**



Estas válvulas se instalan bajo pedido sobre los **REGULADORES HIDRÁULICOS DE VELOCIDAD**. Son válvulas normalmente abiertas, de accionamiento neumático a una

presión máxima de 8 bares y se pueden utilizar separadamente para interceptar fluidos en movimiento.

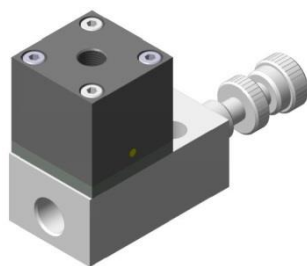

**VA.SKIP4**

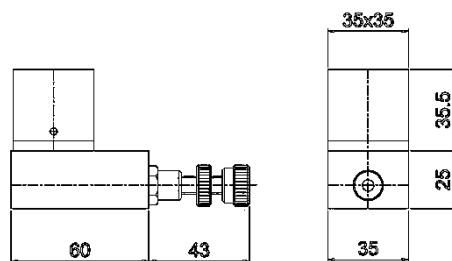
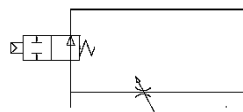

**VA: VALVOLA D'ACCELERAZIONE (SKIP)**



E' normalmente aperta e, in assenza di comando, il fluido passa liberamente escludendo lo spillo di regolazione. Ad un comando pneumatico la valvola chiude il flusso e costringe il fluido a passare attraverso la regolazione, riportando il regolatore alla sua normale funzione.

Questa valvola viene utilizzata quando si necessitano alternanze di movimenti rapidi e controllati.

**VA: ACCELERATION VALVE (SKIP)**



This is normally open, and without any control, the fluid flows freely cutting out the adjustment pin. When a pneumatic control is given, the valve cuts off the flow and forces the fluid through the control valve, returning the regulator to the normal mode.

This valve is used when quick alternating movements are required.

**VA: SOUPE D'ACCELERATION (SKIP)**



Elle est normalement ouverte, et lorsqu'elle n'est pas actionnée, le fluide passe librement, avec inhibition du pointeau de réglage. Lorsque la commande pneumatic est activée, la soupape ferme l'écoulement et oblige le fluide à passer à través le dispositif de réglage, retournant ainsi au fonctionnement normal du régulateur.

Cette soupape s'utilise pour alterner des mouvements rapides et contrôlés.

**VA : VÁLVULA DE ACELERACIÓN (SKIP)**



Normalmente abierta. En ausencia de un comando, el fluido pasa libremente inhibiendo el punzón de regulación. Al darse un comando neumático la válvula cierra al flujo y obliga el fluido a pasar a través de la regulación, llevando así el regulador a desempeñar su función normal.

Esta válvula se utiliza cuando se necesita alternar movimientos rápidos y controlados.

**Valvole di controllo per regolatori idraulici serie 35-40**  
**Control valves for hydraulic speed regulators Series 35-40**  
**Soupapes de contrôle pour régulateurs de vitesse Séries 35-40**  
**Válvulas de control para reguladores de velocidad Serie 35-40**

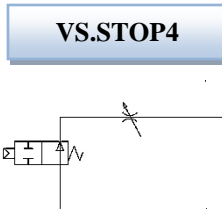
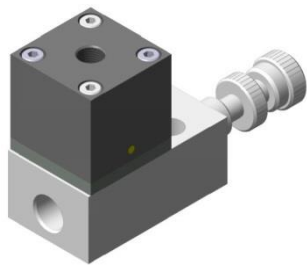

**VS: VALVOLA D'ARRESTO (STOP)**

Il flusso è normalmente controllato dallo spillo di regolazione. Ad un comando pneumatico la valvola interrompe il flusso dell'olio fino all'abbandono del comando pneumatico. Questa talvolta viene utilizzata quando vengono richiesti degli arresti immediati e di precisione.

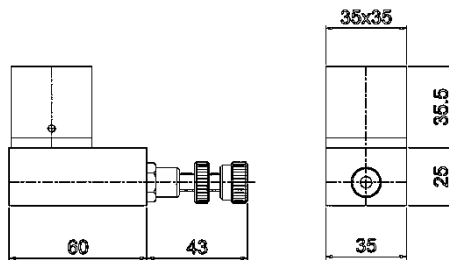

**VS: STOP VALVE (STOP)**

The flow is normally controlled by the regulation pin. When a pneumatic control is given, the valves cuts off the flow of oil until the pneumatic command is removed. This valve is used when immediate accurate stops are required.



**VS: SOUPAPE D'ARRÊT (STOP)**

L'écoulement du fluide est normalement contrôlé à travers le pointeau de réglage. Lorsque la commande pneumatique est activée, la soupape ferme l'écoulement jusqu'à que la commande pneumatique soit coupée. Cette soupape est montée pour basculer des mouvements rapides et contrôlés.



**VS: VÁLVULA DE CIERRE (STOP)**

El flujo está normalmente controlado por el punzón de regulación. Al darse un comando neumático, la válvula interrumpe el flujo de aceite hasta que se abandona el comando neumático. Esta válvula se utiliza cuando se necesitan paradas inmediatas y de precisión.

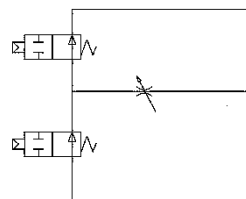
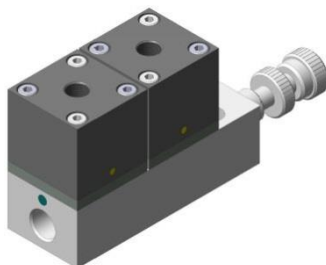

**AS.SKIP+STOP**



**AS: VALVOLA COMBINATA  
ACCELERAZIONE E ARRESTO (SKIP+STOP)**

Somma le caratteristiche delle valvole precedentemente descritte, che possono essere fornite abbinate su un unico modulo.

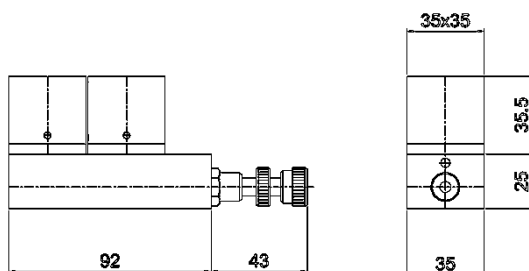

**AS: ACCELERATION + STOP VALVE  
COMBINED (SKIP+STOP)**

This valve sums the features of the above two valves which can be combined in a single module.



**AS: SOUPAPE ACCELERATION + ARRÊT COMBINÉ (SKIP+STOP)**

Inclue les caractéristiques des soupapes décrites ci-dessus, qui peuvent être combinées sur un seul module.



**AS: VÁLVULA DE ACELERACIÓN Y DE CIERRE COMBINADA (SKIP+STOP)**

Suma las características de los dos tipos de válvula descritos anteriormente, asociadas en unico módulo.

Valvole di controllo speciali (pressione max 35 bar)  
 Special control valves (max. pressure 35 bar)  
 Soupapes de contrôle spéciales (pression max 35 bar)  
 Válvulas de control especiales (presión max. 35 bares)



VSC. U 1/4

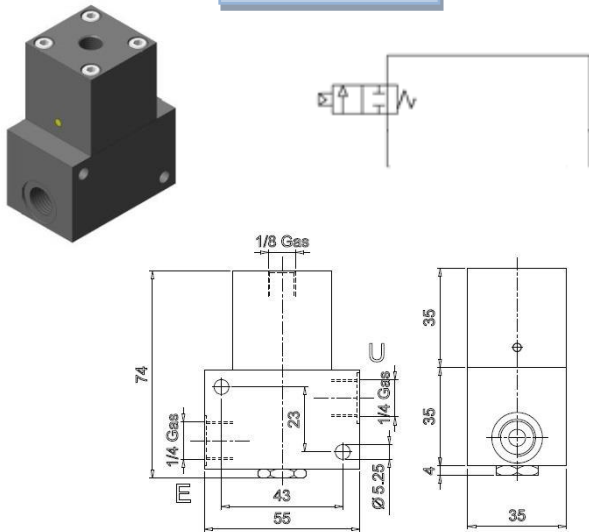

VRF. 1/4

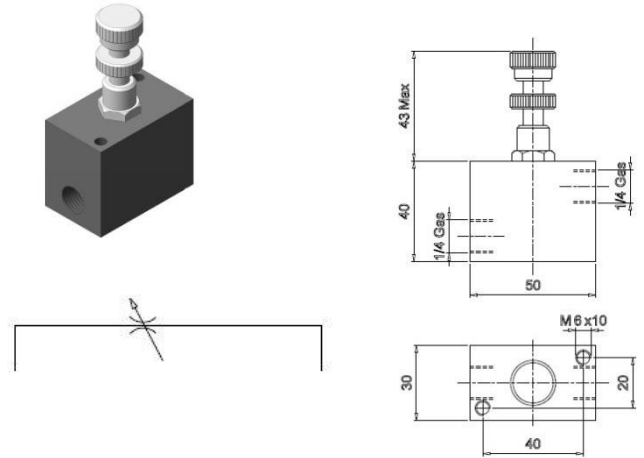

VRF. 3/8 BY

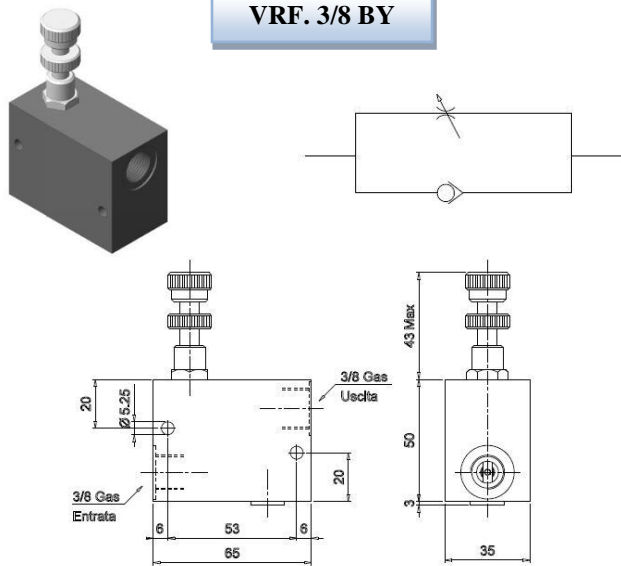

VS. 1/4 1/8

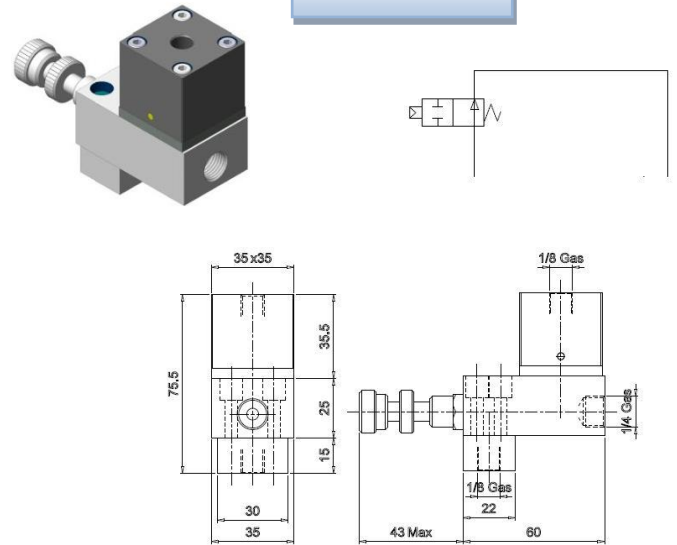

VSC STOP

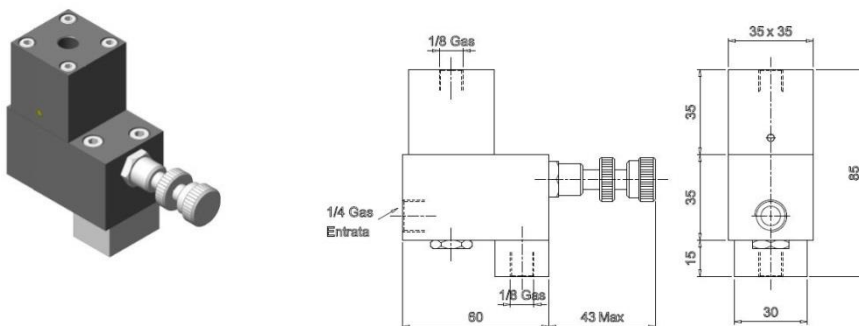

# Valvole di controllo speciali (pressione max 35 bar)

## Special control valves (max. pressure 35 bar)

### Soupapes de contrôle spéciales (pression max 35 bar)

#### Válvulas de control especiales (presión max. 35 bares)



#### VSC. U 1/4 – VALVOLA DI BLOCCO UNIDIREZIONALE NORMALMENTE CHIUSA

Valvola di blocco unidirezionale normalmente chiusa a comando pneumatico, nel caso d'interruzione dell'aria, la valvola blocca il flusso dell'olio in una sola direzione, consentendo il ritorno libero.

#### VRF. 1/4 – VALVOLA DI REGOLAZIONE E DI FLUSSO BIDIREZIONALE

La valvola consente la regolazione del flusso in entrambi i sensi agendo manualmente sul volantino zigrinato. Viene usata per regolare il flusso di olio nei circuiti o nei travasi d'olio da serbatoi dove la spinta è pneumatica.

#### VRF. 3/8 BY – VALVOLA DI REGOLAZIONE DI FLUSSO UNIDIREZIONALE

La valvola ha la funzione di regolare il flusso dell'olio in una sola direzione consentendo il ritorno libero tramite un by-pass.

#### VS.1/4.1/8 – VALVOLA DI STOP NORMALMENTE APERTA CON REGOLAZIONE DI FLUSSO

La valvola è uguale al tipo montato sui regolatori, ha la funzione di regolare il flusso dell'olio o di bloccare il flusso con un comando pneumatico. Il passaggio limitato non consente il ritorno rapido dell'olio.

#### VSC.STOP – VALVOLA DI STOP NORMALMENTE CHIUSA CON REGOLAZIONE DI FLUSSO

La valvola ha la funzione di regolare il flusso dell'olio o di bloccare il flusso per una casuale interruzione dell'aria. Impiegata su impianti dove si necessita un intervento di sicurezza.



#### VSC.U 1/4 - N.C. ONE-WAY STOP VALVE

Normally closed one-way stop valve with pneumatic control. If the air flow is cut off, the valve stops oil flow in one direction and allows the return flow.

#### VRF.1/4 – TWO-WAY FLOW CONTROL VALVE

This valve enables you to control the flow in both directions by turning the knurled hand knob. It is used to control oil flow in circuits or when the thrust is pneumatic.

#### VRF.3/8 BY – ONE-WAY FLOW CONTROL VALVE

This valve is used to regulate oil flow in one direction and it allows return flow through a by-pass.

#### VS.1/4.1/8 – N.O. STOP VALVE WITH FLOW REGULATION

This valve is similar to that one mounted into regulators. It regulates or cuts off oil flow by pneumatic control. The small passage does not allow the oil rapid return.

#### VSC.STOP – N.C. STOP VALVE WITH FLOW REGULATION

This valve regulates or cuts off oil flow when the air supply is cut off. It is used in systems requiring safety cut off devices.



#### VSC. U 1/4 - SOUPAPE DE BLOCAGE UNIDIRECTIONNELLE NORMALEMENT FERMÉE

Soupape de blocage unidirectionnelle fermée à commande pneumatique; en cas d'interruption d'air, la soupape bloque l'huile dans une seule direction et permet le retour libre.

#### VRF. 1/4 – SOUPAPE DE BLOCAGE ET DE DEBIT BIDIRECTIONNELLE

Cette soupape permet de réguler le débit dans les deux sens par le réglage du bouton moleté. Elle est utilisée pour réguler le débit d'huile dans les circuits, ou pour la transfère d'huile des réservoirs où il y a une poussée pneumatique.

#### VRF. 3/8 BY – SOUPAPE DE REGLAGE DE DEBIT UNIDIRECTIONNELLE

Cette soupape a pour fonction de réguler le débit d'huile dans une seule direction et de permettre le retour à travers d'un by-pass.

#### VS. 1/4.1/8 – SOUPAPE D'ARRET NORMALEMENT OUVERTE AVEC REGLAGE DE DEBIT

Cette soupape est similaire à celles installées sur les régulateurs; elle a pour fonction de réguler le débit d'huile et de bloquer l'écoulement par une commande pneumatique. Le passage limité ne permet pas le retour rapide de l'huile.

#### VSC.STOP – SOUPAPE D'ARRET NORMALEMENT FERMÉE AVEC REGLAGE DE DEBIT

Cette soupape a pour fonction de réguler le débit d'huile et de bloquer l'écoulement en cas d'une interruption d'air. S'utilise sur les installations ayant besoin de dispositifs d'arrêt de sécurité.



#### VSC. U 1/4 – VÁLVULA DE BLOQUEO UNIDIRECCIONAL NORMALMENTE CERRADA

Válvula de bloqueo unidireccional normalmente cerrada de mando neumático, en caso de interrupción del aire, la válvula bloquea el flujo de aceite en una sola dirección, permitiendo el regreso libre.

#### VRF. 1/4 – VÁLVULA DE REGULACIÓN DE FLUJO BIDIRECCIONAL

La válvula permite la regulación del flujo en los dos sentidos, actuando manualmente sobre el volante moleteado. Se utiliza para regular el flujo de aceite en los circuitos o en los transvases de aceite desde depósitos en los que la impulsión es neumática.

#### VRF. 3/8 BY – VÁLVULA DE REGULACIÓN DE FLUJO UNIDIRECCIONAL

La válvula tiene la función de regular el flujo de aceite en una sola dirección, permitiendo el regreso libre mediante un by-pass.

#### VS. 1/4.1/8 – VÁLVULA DE CIERRE NORMALMENTE ABIERTA CON REGULACIÓN DE FLUJO

La válvula es igual a las del tipo montado sobre los reguladores y tiene la función de regular el flujo de aceite o de bloquear el flujo con un comando neumático. El paso ilimitado no permite el regreso rápido del aceite.

#### VSC.STOP - VÁLVULA DE CIERRE NORMALMENTE CERRADA CON REGULACIÓN DE FLUJO

La válvula tiene la función de regular el flujo de aceite o de bloquear el flujo debido a una casual interrupción del aire. Se utiliza sobre equipos en los que se necesita una intervención de seguridad.

**FLANGIA – FLANGE – FLANGE – BRIDA**

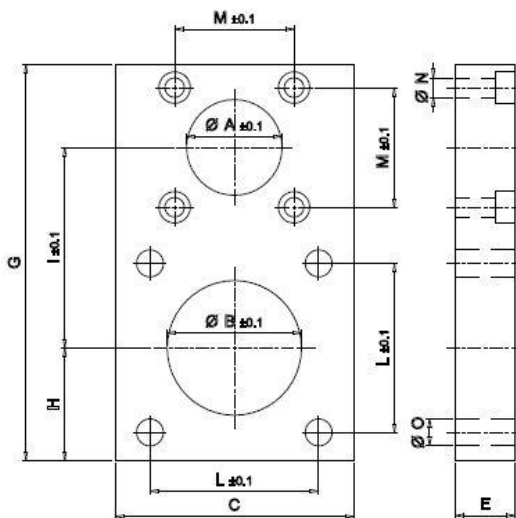
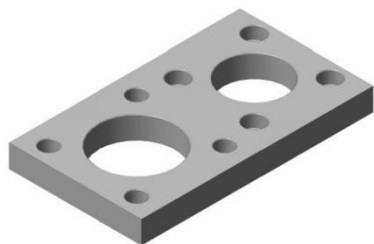

	A	B	C	E	G	H	I	L	M	N	O
<b>FL.40.40</b>	32	35	60	12	110	26.5	56	38	40	6.5	7
<b>FL.40.50</b>	32	40	70	12	122	32.5	62	46.5	40	6.5	9
<b>FL.40.63</b>	32	45	80	20	132	37.5	67	56.5	40	6.5	9
<b>FL.40.80</b>	32	45	100	20	152	47.5	77	72	40	6.5	11
<b>FL.40.100</b>	32	55	110	15	170	56.5	86.5	89	40	6.5	11

**BRIGLIA – BRIDE – FLANGE – BRIDA**

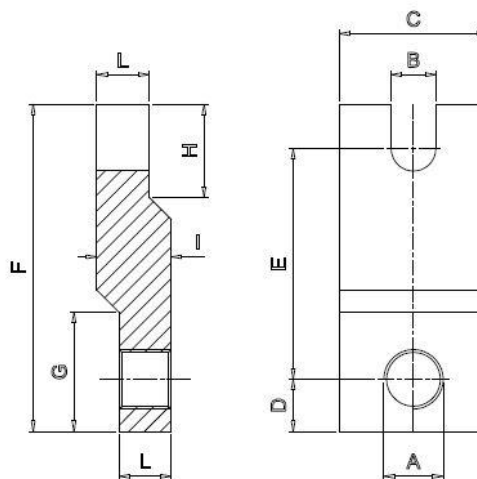

	A	B	C	D	E	F	G	H	I	L
<b>BR.40.40</b>	M12x1.25	12	40	12	56	80	25	25	20	14
<b>BR.40.50</b>	M16x1.5	12	40	14	62	88	32	25	20	14
<b>BR.40.63</b>	M16x1.5	12	40	14	67	93	32	25	20	14
<b>BR.40.80</b>	M20x1.5	12	50	18	77	107	-	-	20	-
<b>BR.40.100</b>	M20x1.5	12	50	18	77	117	-	-	20	-

NIPPLO – ADAPTER – ADAPTEUR – ADAPTADOR

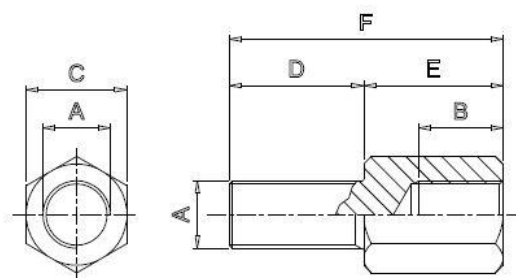

MODELLO - MODEL MODÈLE - MODELO	A	B	C	D	E	F
NL40.40	M12x1.25	14	19	24	23	47
NL40.50/63	M16x1.5	20	24	32	33	65
NL40.80	M20x1.5	25	30	40	38	78

**KIT DI FISSAGGIO PER REGOLATORI SERIE 40 CON CILINDRI SERIE “ISO”, alesaggio 40÷100 mm**  
**FASTENING KIT FOR HYDRAULIC REGULATORS 40 SERIES WITH CYLINDER “ISO”, bores 40÷100 mm**  
**KIT DE FIXAGE POUR RÉGULATEURS HYDRAULIQUES SÉRIES 40 AVEC VÉRINS SERIES “ISO”, alésage 40÷100 mm**  
**KIT DE FIJACIÓN REGULADORES HYDRÁLICOS SERIE 40 CON CILINDROS SERIE “ISO”, diámetro interior 40÷100 mm**



**ESEMPIO DI ACCOPPIAMENTO**

Disponibili in 5 modelli

Gruppo per il fissaggio di regolatori idraulici serie 40, con cilindri serie “ISO” alesaggio 40÷100 mm.

Il gruppo è composto da: flangia di fissaggio regolatore/cilindro pos. ①, briglia di collegamento steli pos. ②, barra filettata da 200 mm pos. ③, nipplo di ripristino filetto cilindro pos. ④.



**COMBINATION EXAMPLE**

5 models available

Fastening group for hydraulic regulators 40 series, with cylinders “ISO” series bore 40÷100 mm.

The group is composed by: fastening bridle regulator/cylinder pos. ①, bridle for rod union pos. ②, 200 mm threaded bar pos. ③, cylinder threaded adapter pos. ④.



**EXEMPLE DE COUPLAGE**

5 modèles disponibles

Groupe pour le fixage des régulateur hydrauliques séries 40, avec vérin séries “ISO” alésage 40÷100 mm.

Les composants du groupe : flange de fixage régulateur/vérin pos. ①, flange d’union des tiges pos. ②, tige filetée 200 mm pos. ③, rallonge du filet des tiges pos. ④.



**EJEMPLO DE COMBINACION**

disponibles en 5 modelos

Grupo de fijación para reguladores hydraulicos serie 40, con cilindros serie “ISO” diametro interior 40÷100 mm.

El grupo incluye: brida de fijación regulador/cilindro pos. ①, brida de union vastagos pos. ②, barra roscada 200 mm pos. ③, adaptador de filete cilindro pos. ④.

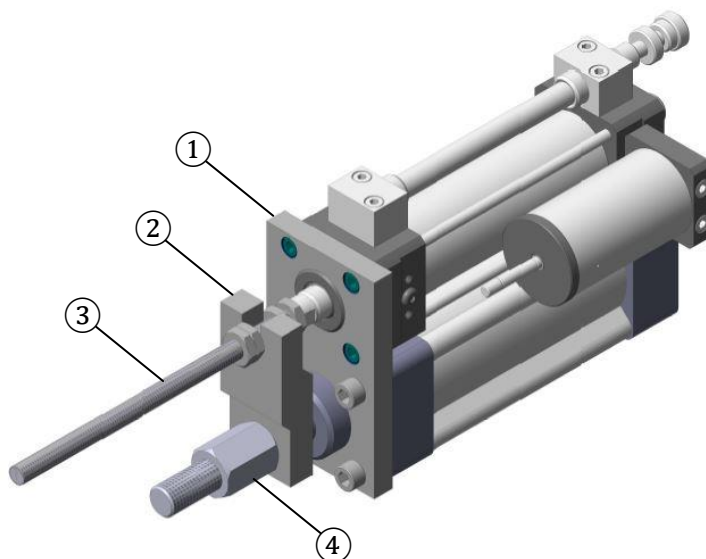

MODELLI DISPONIBILI MODÈLES DISPONIBLES	AVAILABLE MODELS MODELOS DISPONIBLES
KIT.40.40	KIT.40.50
KIT.40.63	KIT.40.80
KIT.40.100	



 **OLIO SPECIALE**  
Olio speciale per regolatori idraulici di velocità.  
Confezione da 1l.

**OLIR 25/S** – Olio silconico (viscosità 250 cSt) per miniregolatori serie RLE.25

**OLIR 40** – Olio idraulico minerale (classe H, simbolo ISO UNI HG46, viscosità 4,5 Engler a 40°C) per regolatori serie 35 e 40.

 **SPECIAL OIL**  
Special oil for hydraulic speed regulators.  
Comes in 1-litre containers.

**OLIR 25/S** – Silicon oil (250 cSt viscosity) for mini-regulators RLE 25 series.

**OLIR 40** – Hydraulic mineral oil (H class, HG46 ISO UNI symbol, 4,5 Engler viscosity at 40°C) for regulators 35 and 40 series.

 **HUILE SPÉCIAL**  
Huile spécial pour régulateurs hydrauliques de vitesse. Bidon de 1 litre  
**OLIR 25/S** – Huile au silicone (viscosité 250 cSt) pour mini régulateurs séries RLE 25.

**OLIR 40** – Huile hydraulique minéral (class H, symbole ISO UNI HG46, viscosité 4,5 Engler à 40°C) pour régulateurs séries 35 et 40.

 **ACEITE ESPECIAL**  
Aceite especial para reguladores hidráulicos de velocidad.  
Envase de litro 1.

**OLIR 25/S** – Aceite silicónico (viscosidad 250 cSt) para mini-reguladores serie RLE 25.

**OLIR 40** – Aceite hidráulico mineral (clase H, símbolo ISO UNI HG46, viscosidad 4,5 Engler a 40°C) para reguladores series 35 y 40.

 **BARRE FILETTATE**  
Disponibili in 4 misure, complete di 5 dadi e 2 rondelle di rame.  
Vengono normalmente usate per il prolungamento degli steli dei regolatori serie 35 e 40.

 **THREADED BARS**  
Available in 4 sizes. Complete with 5 nuts and 2 copper washers.  
Normally used to extend series 35 and 40 piston rods.

 **TIGES FILETÉES**  
Disponible en 4 tailles. Fournies complètes avec 5 écrous et 2 rondelles en cuivre. Elles sont normalement utilisées pour la rallonge des tiges de régulateurs de la série 35 et 40.

 **BARRAS ROSCADAS**  
Disponibles en 4 tamaños. Están dotados de 5 tuercas y de 2 arandelas de cobre. Se utilizan normalmente como prolongación de los vástagos de los reguladores de serie 35 y 40.



DIMENSIONI DI MONTAGGIO – ASSEMBLY DIMENSIONS  
DIMENSIONS DE MONTAGE – TAMAÑOS DE MONTAJE

MODELLO - MODEL MODÈLE - MODELO	Dimensioni – Dimensions Dimensions - Tamaños	
	L	
<b>BF.200</b>	200	
<b>BF.300</b>	300	
<b>BF.400</b>	400	
<b>BF.500</b>	500	

## GHIERE – RING NUTS – ECRIOUS - ABRAZADERAS

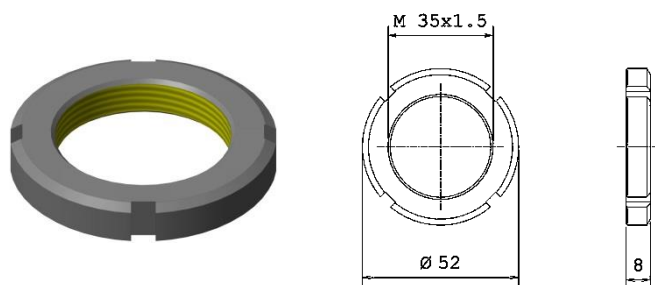

DIMENSIONI DI MONTAGGIO – ASSEMBLY DIMENSIONS  
DIMENSIONS DE MONTAGE – TAMAÑOS DE MONTAJE

MODELLO - MODEL MODÈLE - MODELO	Dimensioni – Dimensions Dimensions - Tamaños		
	C	D	X
<b>GF.35</b>	52	M35x1,5	8

 **POMPA MANUALE DI RICARICA**  
Pompa per il riempimento dei regolatori idraulici serie 35 e 40

 **HAND RECHARGE PUMP**  
Pump for filling series 35 and 40 hydraulic speed regulators

 **POMPE MANUELLE DE REMPLISSAGE**  
Pompe pour le remplissage des régulateurs de la série 35 et 40.

 **BOMBA MANUAL DE RECARGA**  
Bomba para llenar los reguladores serie 35 y 40

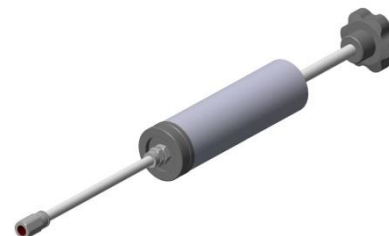

DIMENSIONI DI MONTAGGIO – ASSEMBLY DIMENSIONS  
DIMENSIONS DE MONTAGE – TAMAÑOS DE MONTAJE

MODELLO - MODEL MODÈLE - MODELO	Capacità – Capacity Capacità - Capacidad
<b>45.40.80</b>	cm <sup>3</sup> 98

# Regolatori idraulici di velocità – Serie 35 e Serie 40

## Hydraulic speed regulators – 35 and 40 series



### ISTRUZIONI PER CARICAMENTO OLIO DOPO INTERVENTO DI MANUTENZIONE



Elementi necessari: pompa manuale art. 45.40.80, lattina olio idraulico minerale art. OLIR 40 (OLEOL HG46 viscosità 4,5 ENGLER a 40°C)  
(vedi pag. accessori)

Altri oli compatibili secondo le tabelle UNI: AGIP: EXIDIA, ESSO: FEBIS K, SHELL:TONNA OIL, BP: ENERGOL GHL

### **⚠ SI RACCOMANDA L'IMPIEGO DI OLIO IDRAULICO MINERALE CLASSE H SIMBOLO ISO-UNI HG 46**

Si consiglia di effettuare il caricamento con il freno in posizione verticale.

1. Togliere il tappo pos. ① sulla valvola di caricamento pos. ②.
2. Collegare la pompa ② alla valvola di caricamento pos. ②, girare la manopola ③ fino a quando si vedrà la tacca di livello ④ sull'astina del serbatoio.
3. Tirare lo stelo ⑤ tutto fuori.
4. Staccare la pompa ② dalla valvola di caricamento pos. ② ed agire con uno spillo o altro sulla sfera della valvola stessa favorendo la fuoriuscita di possibili bolle d'aria.
5. Portare lo stelo ⑤ tutto dentro.
6. Ricollegare la pompa ② alla valvola di caricamento pos. ② e mettere altro olio fino a quando non si vedrà la tacca di livello ④ sull'astina del serbatoio.
7. Tirare lo stelo ⑤ tutto in fuori.
8. Staccare la pompa ② dalla valvola di caricamento pos. ② ed agire con uno spillo o altro sulla sfera della valvola stessa favorendo la fuoriuscita di possibili bolle d'aria.
9. Portare lo stelo ⑤ tutto dentro.
10. Ripetere le varie fasi, fino a quando dalla valvola di caricamento pos. ② non uscirà più aria, ma soltanto olio.
11. Ricollegare la pompa ② alla valvola di caricamento pos. ② e girare la manopola ③ fino a quando non si vedrà la tacca di livello ④ sull'astina del serbatoio.
12. Staccare la pompa ② e riavvitare il tappo pos. ① sulla valvola di caricamento pos. ②.



### INSTRUCTIONS FOR OIL CHARGE AFTER MAINTENANCE OPERATIONS

Required parts: hand pump item 45.40.80, hydraulic mineral oil item OLIR 40 (OLEOL HG46 4,5 ENGLER viscosity at 40°C)  
(see at accessory page)

Other compatible oils from UNI tables: AGIP:EXIDIA, ESSO: FEBIS K, SHELL:TONNA OIL, BP:ENERGOL GHL

### **⚠ IT'S RECOMMENDED TO USE HYDRAULIC MINERAL OIL "H" CLASS, ISO-UNI HG 46 SYMBOL**

We advise you to do oil charge with speed regulator in vertical position.

- 1<sup>st</sup>. Remove the cap pos. ① on charge valve pos. ②;
- 2<sup>nd</sup>. Connect the ② pump to charge valve pos. ②, turn ③ knob until you see the level line ④;
- 3<sup>rd</sup>. Pull ⑤ piston rod all outside;
- 4<sup>th</sup>. Take off ② pump from charge valve pos. ② and act on the sphere of the same valve with a pin or other, in order that air bubbles come out;
- 5<sup>th</sup>. Lead ⑤ piston rod all inside;
- 6<sup>th</sup>. Reconnect ② pump to charge valve pos. ② and fill a little more till is possible to see the level line ④;
- 7<sup>th</sup>. Pull ⑤ piston rod all outside;
- 8<sup>th</sup>. Take off ② pump from charge valve pos. ② and act on the sphere of the same valve with a pin or other, in order that air bubbles come out;
- 9<sup>th</sup>. Lead ⑤ piston rod all inside;
- 10<sup>th</sup>. Repeat each phase up to oil only come out from the valve pos. ②.
- 11<sup>th</sup>. Connect the ② pump to charge valve pos. ②, turn ③ knob until you see the level line ④;
- 12<sup>th</sup>. Remove the ② pump and screw the cap pos. ① on charge valve pos. ②.



### INSTRUCTIONS POUR LE RECHARGEMENT D'HUILE APRES MAINTENANCE

Composants nécessaires : pompe de remplissage 45.40.80 , huile hydraulique minéral OLEOL HG46 4,5 Engler viscosité à 40°C (voir la page des accessoires)  
Huiles compatibles : AGIP= EXIDIA, ESSO= FEBIS K, SHELL=TONNA OIL, BP=ENERGOL GH

**⚠ NOUS RECOMMANDONS D'EMPLOYER SEULEMENT HUILES SPÉCIFIQUES : CLASS : H SIMBOL : HG VISCOSITE' : 46**

**Nous conseillons de poser le régulateur en position vertical;**

1. Dévisser le bouchon ① sur la valve ②;
2. Attacher la pompe ③ à la valve ②, remplir le régulateur ④ en tournant la manivelle ⑤ jusqu'à quand il est possible voir le niveau ⑥ sur le réservoir;
3. Extraire la tige ⑦ totalement à l'extérieur;
4. Détacher la pompe ③ et pousser le sphère dans la valve ② pour faire sortir possibles boules d'air;
5. Pousser la tige ⑦ toute à l'intérieur;
6. Attacher encore une fois la pompe ③ à la valve ② et remplir encore jusqu'à quand il est possible voir le niveau ⑥ ;
7. Extraire la tige ⑦ totalement à l'extérieur;
8. Détacher la pompe ③ et pousser le sphère dans la valve ② pour faire sortir possibles boules d'air;
9. Pousser la tige ⑦ toute à l'intérieur;
10. Répéter les phases jusqu'à quand l'huile seulement sort par la valve ② (il n'y a plus air dans le circuit);
11. Attacher la pompe ③ à la valve ②, tourner la manivelle ⑤ jusqu'à quand il est possible voir le niveau ⑥ sur le réservoir;
12. Enlever la pompe ③ et revisser le bouchon ① sur la valve ②.

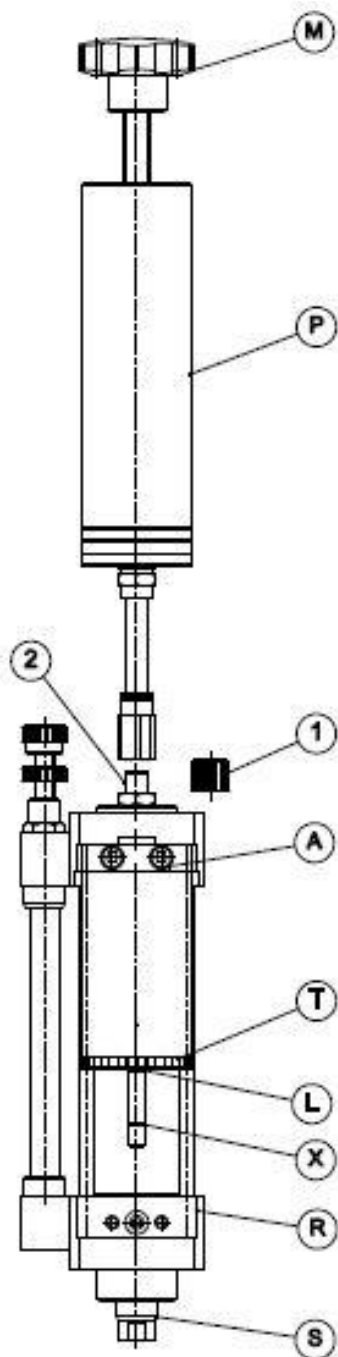

### INSTRUCCIONES PARA EL LLENADO DE ACEITE DESPUES MANTENIMIENTO

Prerrequisitos: bomba manual de recarga de aceite codigo 45.40.80, aceite hidraulico mineral OLEOL HG46 de viscosidad 4.5 Engler a 40°C (consulte la página de los accesorios)

Aceites compatibles:  
AGIP = EXIDIA, K FEBIS de ESSO, SHELL TONNA OIL, BP ENERGOL GH

**⚠ RECOMENDAMOS USAR SÓLO ACEITES ESPECÍFICOS: CLASE: H SÍMBOLO: HG VISCOSIDAD: 46**

**Se aconseja colocar el regulador de posición vertical.**

1. Desenroscar el tapón ① sobre la válvula ②;
2. Conectar la bomba ③ a la válvula ②, llenar el regulador ④ girando la manivela ⑤ hasta que sera posible ver el nivel ⑥ sobre el tanque;
3. Extraer el vástago ⑦ totalmente hacia el exterior;
4. Desconectar la bomba ③ y empujar la esfera de la válvula ② para quitar las bolas de aire posibles;
5. Empujar el vástago ⑦ totalmente hacia el interior;
6. Fijer nuevamente la bomba ③ a la válvula ② y llenar con aceite hasta es posible ver el nivel ⑥
7. Extraer el vástago ⑦ totalmente hacia el exterior;
8. Desconectar la bomba ③ y empujar la esfera de la válvula ② para quitar las bolas de aire posibles;
9. Empuje el vástago ⑦ totalmente hacia al interior;
10. Fases de repetición hasta que aceite solamente sale a través de la válvula ② (no hay más aire en el circuito);
11. Roscar la bomba ③ hasta que es posible ver el nivel ⑥
12. Desconectar la bomba ③ y roscar el tapón ① sobre la válvula ②.



### ISTRUZIONI PER IL RABBOCCO PERIODICO DI OLIO

**⚠ SI RACCOMANDA L'IMPIEGO DI OLIO IDRAULICO MINERALE CLASSE H SIMBOLO ISO-UNI HG 46**

Il rabbocco deve essere eseguito quando nella posizione “stelo tutto fuori” la tacca di livello ⊗ sarà vicina al tappo ⊕

1. Togliere il tappo pos. ① sulla valvola di caricamento pos. ②;
2. Portare lo stelo ⊙ tutto dentro;
3. Collegare la pompa ⊕ alla valvola di caricamento pos. ②, girare la manopola ⊕ fino a quando si vedrà la tacca di livello ⊕ sull'astina;
4. Staccare la pompa ⊕ e riavvitare il tappo pos. ① sulla valvola di caricamento pos. ②.



### INSTRUCTIONS FOR PERIODICAL OIL FILLING

**⚠ IT'S RECOMMENDED TO USE HYDRAULIC MINERAL OIL “H” CLASS, ISO-UNI HG 46 SYMBOL**

The periodical oil filling should be executed when, with the piston rod all outside, the level line ⊗ will be near the cap ⊕

1. Remove the cap pos. ① on charge valve pos. ②;
2. Lead ⊙ piston rod all inside;
3. Connect the pump ⊕ to charge valve pos. ②, turn ⊕ knob until you see the level line ⊕;
4. Remove the pump ⊕ and screw the cap pos. ① on charge valve pos. ②.



### INSTRUCTIONS POUR LE RECHARGEMENT RECURRENT D'HUILE

**⚠ NOUS RECOMMANDONS D'EMPLOYER SEULEMENT HUILES SPÉCIFIQUES : CLASS : H SIMBOL : HG VISCOSITE' : 46**

Le recharge doit être fait quand, en position « tige toute dehors », le niveau ⊗ se trouve en proximité du bouchon ⊕.

1. Dévisser le bouchon ① sur la valve ②;
2. Pousser la tige ⊙ toute à l'intérieur ;
3. Attacher la pompe de remplissage ⊕ à la valve ②, tourner la manivelle ⊕ jusqu'à quand il est possible voir le niveau ⊕ sur le réservoir;
4. Enlever la pompe ⊕ et visser le bouchon ①.



### INSTRUCCIONES PARA EL LLENADO RECURRENTE DE ACEITE

**⚠ RECOMENDAMOS USAR SÓLO ACEITES ESPECÍFICOS: CLASE: H SÍMBOLO: HG VISCOSIDAD: 46**

Llenar el regulador con aceite cuando, en posición “vástago todo fuera”, el nivel ⊗ se encuentra en proximidad del tapón ⊕

1. Desenroscar el tapón ① sobre la válvula ②;
2. Empujar el vástago ⊙ totalmente hacia el interior;
3. Conectar la bomba de recarga ⊕ a la válvula ②, girando la manivela ⊕ hasta que sera posible ver el nivel ⊕ sobre el tanque;
4. Desconectar la bomba ⊕ y rosca el tapón ①

**NOTE – NOTES**  
**NOTES - NOTAS**



A series of horizontal dotted lines spanning the width of the page, intended for handwritten notes.

**NOTE – NOTES**  
**NOTES - NOTAS**



A series of horizontal dotted lines spanning the width of the page, intended for handwritten notes.



**ENER FLUID di Piovanelli F.lli SNC**

**Tel. 0039 30 9636049 fax 0039 30 9637700**

**[info@enerfluidsnc.com](mailto:info@enerfluidsnc.com)**

**[www.enerfluid.eu](http://www.enerfluid.eu)**

**Sede legale**

**Sede operativa**

**Via GAVARDINA DI SOPRA TRV. I NR. 5  
25010 PONTE SAN MARCO (BS) ITALY**

**Via GAVARDINA DI SOPRA TRAV. II NR. 3  
25010 PONTE SAN MARCO (BS) ITALY**

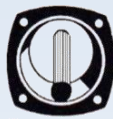

**ENERFLUID**

VISIT OUR WEB SITE FOR OUR COMPLETE RANGE

[www.enerfluid.eu](http://www.enerfluid.eu)



POWER UNITS



CYLINDERS



BOOSTERS

